

SCHOOL OF PLANNING AND ARCHITECTURE, BHOPAL

(An institution of national importance, Ministry of HRD, Govt. of India)

Neelbad Road, Bhauri, Bhopal - 462030



TENDER DOCUMENT

Name of work: Construction of football ground with stage for SPA Bhopal at Bhauri, Bhopal (M.P.).

Issued to: ~~~~~
~~~~~  
~~~~~

Issued by:

Institute Works Department (IWD)

SPA Bhopal

SCHOOL OF PLANNING AND ARCHITECTURE, BHOPAL

(An institution of national importance, Ministry of HRD, Govt. of India)

Neelbad Road, Bhauri, Bhopal - 462030

INDEX

Name of work: Construction of football ground with stage for SPA Bhopal at
Bhauri, Bhopal (M.P.)

| SECTIONS | PERTICULARS | PAGE NO. |
|----------|------------------------------------|---------------------------------------|
| 01 | Tender form | 01-05 |
| 02 | Instructions to Bidders | 06-12 |
| 03 | General Conditions of Contract | Refer at office of IWD, SPA Bhopal 13 |
| 04 | Appendix | Refer at office of IWD, SPA Bhopal 13 |
| 05 | Forms of Bid & Forms of Securities | 14-33 |
| 06 | Bill of Quantities | 34 ~ 41 |
| 07 | Technical specifications | 43-55 |
| 08 | Bid Drawings | 56 (Dwgs attached) |

SECTION 1
Tender Form**Table of contents**

| S.N. | Particulars | Page No. |
|-------------|---|-----------------|
| 01 | Tender form | 02 |
| 02 | List of Important Dates of Bids | 03 |
| 03 | Notice Inviting Tender published in Press | 04 |

SCHOOL OF PLANNING AND ARCHITECTURE, BHOPAL

(An institution of national importance, Ministry of HRD, Govt. of India)

Neelbad Road, Bhauri, Bhopal - 462030

Tender Form

Name of work: Construction of football ground with stage for SPA Bhopal at Bhauri, Bhopal (M.P.)

Project Number: Advt./2015-16/RGO/10.....

Probable amount of Contract: Rs. **95 Lacs (Approx.)**.....

Cost of Tender Form: Rs. **5000/-**.....

Paid vide DD No. Dated

Time allowed for Completion: **06 months**

Name of contractor/firm:

Address of the firm:

Earnest Money Deposit: Rs.

Paid vide DD No. Dated

Submission date: To be submitted by **17:00 hours** on**07 September 2015**..... (Date)

Opening date: Technical bid to be opened at **11:00 hours** on **08 September 2015**.. (Date)

Financial bid to be opened at **11:00 hours** on **09 September 2015**..(Date)

Place of Submission and Opening: Office of the Dean (P&D), SPA Bhopal

Dean (P&D),

Institute Works Department (IWD),

School of Planning and Architecture (SPA), Bhopal

SCHOOL OF PLANNING AND ARCHITECTURE, BHOPAL

(An institution of national importance, Ministry of HRD, Govt. of India)

Neelbad Road, Bhauri, Bhopal - 462030

List of Important Dates of Bids

1. Name of Work:

Construction of foot ball ground with stage for SPA Bhopal at Bhauri, Bhopal (M.P.).

- | | |
|---|---------------------------------|
| 2. Completion Period for construction/up gradation: | 06 months |
| 3. Date of Issue of Notice Inviting Bid | Date-26-Month-08-Year-2015 |
| 4. Date for downloading of Tender documents - | From Date-26-Month-08-Year-2015 |
| | to Date-07-Month-09-Year-2015 |
| | Place (s) as given in NIT |
| 5. Deadline for Receiving Bid | Date-07-Month-09-Year-2015 |
| | Time ...17:00...Hours |
| 6. Time and Date for opening Technical Bid/Bids | Date-08-Month-09-Year-2015 |
| | Time ...11:00...Hours |
| 7. Time and Date of opening Financial Bids | Date-09-Month-09-Year-2015 |
| | Time ...11:00...Hours |
| 8. Place of opening bids Address is: | As given in NIT |
| 9. Last Date of Bid Validity | As indicated in NIT |
| 10. Officer inviting Bids: | Director, SPA Bhopal |

Dean (P&D),
Institute Works Department (IWD),
School of Planning and Architecture (SPA), Bhopal

SCHOOL OF PLANNING AND ARCHITECTURE, BHOPAL

(An institution of national importance, Ministry of HRD, Govt. of India)

Neelbad Road, Bhauri, Bhopal - 462030

Notice Inviting Tenders

1. SPA Bhopal, invites sealed **Item rate tenders** in three envelope system from Contractors registered in appropriate class with CPWD or Contractors of equivalent categories registered with other States/Central Government department, institutions, undertakings and authorities for following works of Construction of football ground with stage for SPA Bhopal at Bhauri, Bhopal (M.P.)

| Description of Works | Estimated cost | EMD | Period of completion |
|---|---------------------|-----|----------------------|
| Construction of foot ball ground with stage for SPA Bhopal at Bhauri, Bhopal (M.P.) | 95 Lacs (Approx) | 2% | 06 months |

2. The amount of earnest money is **2% of the estimated cost of the project.**
3. Time allowed for completion of entire work is 06 months.
4. The site for the work is available.
5. Bid documents consisting of qualification information and eligibility criterion of bidders, plans, specifications, drawings, the schedule of quantities of the various classes of work to be done and the set of terms & conditions of contract to be complied with by the Contractor can be seen in the office of the **Dean (P&D), SPA Bhopal, Neelbad Road, Bhauri, Bhopal** on any working day during office hours up to **04:30 P.M.**
6. Tender document can be downloaded from the internet www.spabhopal.ac.in. In such cases, the cost of tender document should be submitted along with the EMD in the form of separate Demand Drafts / Pay Orders of a Scheduled Bank drawn in favor of Director, SPA Bhopal.
7. Bidding documents must be delivered to **Dean (P&D), SPA Bhopal, Neelbad Road, Bhauri, Bhopal , Madhya Pradesh (India) – 462030** on or before ...**07 September, 2015**... up to ...**17:00**... hours. If the office happens to be closed on the date of receipt of the bids as specified, the bids will be received on the next working day at the same time and venue.
8. Bidding documents can also be delivered at the following places at the assigned date and time.

To,

The Director, SPA BHOPAL,

Neelbad Road, Bhauri, Bhopal, MP – 462 030

Technical bids will be opened at **11:00** hours. on ...**08 September 2015**... in the office of concerned Dean (P&D), SPA Bhopal, If the office happens to be closed on the date of opening of the bids as specified, the bids will be opened on the next working day at the same time and venue.

9. Financial bids shall be opened on ...**09 September, 2015**... from **11:00** hours at office of the Dean (P&D), SPA Bhopal
10. To qualify for award of the Contract, each bidder should have in the last five years:
 - a. Achieved in any one year during last 5 years (including current year) a minimum financial turnover volume of similar work of at least the amount equal to the estimated cost of works (excluding maintenance cost for five years) for which bid has been invited. The turnover will be indexed at the rate of 8 percent for a year.
 - b. Satisfactorily completed, as prime Contractor, at least one similar work equal in value to one-third of the estimated cost of work for which the bid is invited.
11. Bids must be accompanied by the earnest money of the amount specified for the work in the table. The earnest money will have to be in any one of the forms as specified in the Bidding documents.
12. The bid for the work shall remain open for acceptance for a period of forty five days from the date of opening of bids. If any bidder/ tenderer withdraws his bid/ tender before the said period or makes any modifications in the terms and conditions of the bid, the said earnest money shall stand forfeited.
13. No Engineer of gazetted rank or other Gazetted officer employed in Engineering or Administrative duties in an Engineering Department of the State Government is allowed to work as a Contractor for a period of two years after his retirement from Government service, without Government permission. This contract is liable to be cancelled if either the Contractor or any of his employees is found any time to be such a person who had not obtained the permission of the Government as aforesaid before submission of the tender or engagement in the Contractor's service.
14. Other details can be seen in the bidding documents.

Dean (P&D),
Institute Works Department, SPA BHOPAL

Section 2: Instructions to Bidders

1.0 The tenderers, who have down loaded the tenders from the web, should read the following important instructions carefully before actually quoting the rates & submitting the tender documents: -

- 1.1 The tenderer should see carefully & ensure that the complete tender document including schedule of Quantities have been down loaded & there are55+1..... Pages in all in the tender document.
- 1.2 The printout of tender document should be taken on A4 size paper only.
- 1.3 The tenderer should ensure that no page of the down loaded tender document is missing.
- 1.4 The tenderer should ensure that all pages of the down loaded tender document are legible & clear & are printed on a good quality paper.
- 1.5 The tenderer should ensure that every page of the downloaded tender document is signed by Tenderer with stamp (seal).
- 1.6 The tenderer should ensure that the down loaded tender document is properly bound and sealed before submitting the same.
- 1.7 The loose tenders not properly sealed shall be summarily rejected.
- 1.8 In case of any correction / addition / alteration / omission in the downloaded tender document, it shall be treated as non-Responsive and shall be summarily rejected.
- 1.9 The tenderer shall furnish a declaration to this effect that no addition / correction / alteration / omissions have been made in the tender document submitted, and it is identical to the tender document appearing on Web site (9. Declaration).
- 1.10 The tenderer should read carefully and sign the declaration given before submitting the tender.
- 1.11 In case of partnership firm, an attested copy of partnership deed must be given along with eligibility credentials in envelope - 1.
- 1.12 In case of any doubt in the down loaded tender, the same should be got clarified from the O/o Dean (P&D), IWD, SPA Bhopal before submitting the tender.

2.0 Item rate tenders are invited on behalf of SCHOOL OF PLANNING AND ARCHITECTURE, BHOPAL (An institution of national importance, Ministry of HRD, Government of India) from approved, eligible and registered contractors of Public works organizations like CPWD, MES and local State P.W.D (B&R) for the work of **“Construction of football ground with stage for SPA Bhopal at Bhauri, Bhopal (M.P.)”**

- 1.1 **The work is estimated to Cost Rs. 95 Lacs (approx.)/- (Rs. Ninety five lacs only)**
- 1.2 To qualify for award of the Contract, each bidder should have in the last five years:
 - a. Achieved in any one year during last 5 years (including current year) a minimum financial turnover volume of similar work of at least the amount equal to the estimated cost of

works (excluding maintenance cost for five years) for which bid has been invited. The turnover will be indexed at the rate of 8 percent for a year.

b. Satisfactorily completed, as prime Contractor, at least one similar work equal in value to one-third of the estimated cost of work for which the bid is invited.

It is clarified that the works should be in Central Government/Central Autonomous Bodies/Central Public Sector Undertakings/State Government and the certificate should be issued by the officer not below rank of Executive Engineer/ Project Manager or equivalent.

c. **Similar works:** Means work of ground leveling, concreting, paver tiles and steel work etc.

2. Deleted

3 The time allowed for carrying out the work shall be **06 months** from the day after the date of issue of letter of award of work, or, from the first day of handing over of the site, whichever is later.

4 The site for the work is available.

5 The last date of receipt of application for participation in tender will be as follows:

(i) Last date of receipt of application for participation in tender, **07 September 2015** up to **17:00** hrs

(ii) Last date and time of submission of tender ...**07 September 2015**..... up to **17:00** hrs

(iii) Date and time of opening of tender ...**08 September 2015**..... at **11:00** hrs

6 Tender documents consisting of following:

- (a) Tender form
- (b) Instructions to bidders
- (c) Forms of Bid & Forms of Securities
- (d) Bill of Quantities for works (BOQ)
- (e) Technical Specifications
- (f) Drawings

6.1 Following important documents can be seen in the office of the Dean (P&D), Institute Works Department (IWD) SCHOOL OF PLANNING AND ARCHITECTURE, BHOPAL (MP) Between 11.00 hours. & 15.00 hours every day except on Saturday, Sundays and Public Holidays.

- (a) General condition of the contract,
- (b) Annexure for safety measures, labour provisions, model codes,
- (c) Various forms for bid etc.

6.2 Tender document can be downloaded from the internet www.spabhupal.ac.in.

6.2.1 The cost of the downloaded tender document (Rs. 5000/-) should be submitted along with the EMD in the form of separate Demand Drafts / Pay Orders of a Scheduled Bank drawn in favor of Director, SPA Bhopal.

- 7 Tenders, which should always be placed in sealed envelope, in the manner described at para 9 below with the name of work and due date written on the envelopes, will be received by the Dean (P&D),
Institute Works Department (IWD)
SCHOOL OF PLANNING AND ARCHITECTURE, BHOPAL (MP)
Neelbad Road, Bhauri, Bhopal M.P.-462030
Up to **17.00 Hrs.** on ...**07 September, 2015** (Date) and will be opened by him or his authorized representative in his office on **08 September 2015** at **11:00 Hrs.**
The financial bid shall be opened on ... **09 September, 2015...** (Date) at **11:00 Hrs** by Dean (P&D), or his authorized representative.
- i). After opening the main envelope 3, the envelope 1 containing the “Earnest money” and eligibility credentials shall be opened first.
 - ii). The envelope 2 containing tender shall be opened only for those tenderers whose Earnest money and eligibility is found in order.
 - iii). The unopened tenders shall be returned to the tenderers after the final decision on the tender is reached.
8. The description of the work is as follows: - **“Construction of foot ball ground with stage for SPA Bhopal at Bhauri, Bhopal (M.P.)”**.
- 9.0 **Submission of tender:** The tender shall be submitted in the following manner:
- 9.1 The Bidder shall place the three separate envelopes (called inner envelopes) marked “EMD”, “Technical Bid” and “Financial Bid” in one outer envelope. The inner envelopes will have markings as follows:
- (a) EMD.
 - (b) Technical Bid: To be opened on **08 September 2015** at **11:00 Hrs.**
 - (c) Financial Bid: Not to be opened except with the approval of the Employer.
- 9.1.1 The contents of the Technical bid shall be as follows:
- (a) Qualification information, supporting documents, affidavit and undertaking as specified in *Form 3.Bidder Information*
 - (b) Undertaking that the bid shall remain valid for the period specified in *Form 4.Declaration Statement*
 - (c) Any other information/documents required to be completed and submitted by bidders, as specified in the Tender Document, and
 - (d) An affidavit affirming that information he has furnished in the bidding document is correct to the best of his knowledge and belief. (*Form 13. Affidavit by contractor*)
- 9.1.2 The contents of the Financial Bids shall be as follows:
- (i) Form of Bid as specified in Section 5 (form 8. Letter of financial bid)
 - (ii) Priced bill of quantities for items specified in Section 6;

9.2 All the three envelopes EMD, Technical & Financial Bids shall be superscripted with following data.

(i) Name of work

(ii) Name of tenderer

(iii) Last date of receipt of tender

Note: In case the eligibility credentials are not found in order at any stage i.e. before award of work or during execution of the work or after completion of the work, the contractor will be debarred from tendering in SPA Bhopal for three years including any other action under the contract or existing law.

9.3 The tender in which rates are to be quoted should be properly bound and sealed.

10. Copies of other drawings and documents, if any, pertaining to the work will be open for inspection by the tenderers at the office of the above-mentioned officer.

10.1 Tenderers are advised to inspect and examine the topography of the site and satisfy themselves before submitting their tenders as to the nature of the terrain and sub-soil in general (so far as is practicable), the form and nature of the site, the means of access to the site, the accommodation they may require and in general, shall themselves obtain all necessary information as to risks, contingencies and other circumstances which may influence or affect their tender. Tenderer shall be deemed to have full knowledge of the site & its location whether he inspects it or not and no extra charges consequent on any misunderstanding or otherwise shall be allowed. The tenderer shall be responsible for arranging and maintaining at his own cost all materials tools & plants, water, electricity, access facilities for workers and on all other services required for executing the work unless otherwise specifically provided for in the contract documents. Submission of tender by a tenderer implies that he has read this notice and all other contract documents and has made himself aware of the scope and specifications of the work to be done and of conditions and rates at which stores, tools and plant, etc. will be issued to him by the SPA Bhopal and local conditions and other factors having a bearing on the execution of the work.

11. The competent authority on behalf of SPA Bhopal does not bind himself to accept the lowest or any other tender, and reserves to himself the authority to reject any or all of the tenders received without the assignment of a reason. Any tenders, in which any of the prescribed conditions is not fulfilled or any condition including that of conditional rebate is put forth by the tenderer, shall be summarily rejected.

12. Canvassing whether directly or indirectly, in connection with tenders is strictly prohibited and the tenders submitted by the contractors who resort to canvassing will be liable to rejection.

13. The competent authority on behalf of the SPA Bhopal reserves with himself the right of accepting the whole or any part of the tender and the tenderer shall be bound to perform the same at the rate quoted.

14. The company or firm or any other person shall not be permitted to tender for works in SPA Bhopal in which his near relative (s) (directly recruited or on deputation in SPA Bhopal) is/are posted in any capacity either non-executive or executive employee. Near relative (s) for this purpose is/are defined as: –

(i) Member of Hindu Undivided family (HUF).

(i) They are Husband and Wife.

(ii) The one is related to other in the manner as father, mother, son(s) & Son's wife (daughter-in-law), Daughter(s), Daughter's husband (son-in-law), brother(s), brother's wife, sister(s), sister's husband (brother-in-law).

The contractor shall also intimate the names of persons who are working with him in any capacity or are subsequently employed by him and who are near relative to any executive employee/ officer in the SPA Bhopal.

All the intending tenderers will have to give a certificate that none of his/her such near relative (s) as defined above is/are working in the concerned department where he is going to apply for tender/work. The format of the certificate is to be given as:-

“I, _____ S/O Shri _____ Resident of _____ hereby certify that none of my relative (s) as defined in clause 14 of the notice inviting tender of NIT No. _____ is/are employed in concerned SPA Bhopal. In case at any stage, it is found that the information given by me is false / incorrect, SPA Bhopal shall have the absolute right to take any action as deemed fit without any prior intimation to me”.

The certificate in case of Proprietorship Firm shall be given by the proprietor; for Partnership Firm certificate shall be given by all partners and in case of Limited Company, by all Directors of the company. However, Government of India / Financial Institutions nominees and independent non-official part-time Directors appointed by Govt. of India or the Governor of the State are excluded from the purview of submission of this certificate while submitting tenders by Limited Companies.

Any breach of these conditions by the Company or Firm or any other person, the tender / work will be cancelled and Earnest Money / Security Deposit will be forfeited at any stage, whenever it is so noticed. The department will not pay any damages to the company or Firm or the concerned person. The Company or Firm or the person will also be debarred for further participation in the tender in the concerned SPA Bhopal. Further, any breach of this condition by the tenderer would also render him liable to be removed from the approved list of contractors of this Department. If however the contractor is registered in any other Department he shall also be debarred from tendering in SPA Bhopal for any breach of this condition.

15. No Engineer of Gazetted rank or other Gazetted Officer employed in engineering or administrative duties in an Engineering Department of the Government of India or SPA Bhopal is allowed to work as a contractor for a period of two years after his retirement from Govt.

- service, without previous permission of the Govt. of India or SPA Bhopal in writing. This contract is liable to be cancelled if either the contractor or any of his employees is found any time to be such a person who had not obtained the permission of the Govt. of India or SPA Bhopal as aforesaid before submission of the tender or engagement in the contractor's service.
16. The tender for the work shall remain open for acceptance for a period of 30 days from the date of opening of the tenders. If any tenderer withdraws his tender before the said period issues of letter of acceptance / intent, whichever is earlier or makes any modifications in the terms and conditions of the tender which are not acceptable to the SPA Bhopal, then the SPA Bhopal shall, without prejudice to any other right or remedy, be at liberty to forfeit 50% of the said earnest money as aforesaid.
17. In case of works having estimated cost below Rs.15,00,000/-, the successful tenderer shall be required to execute an agreement with the SPA Bhopal in the Performa annexed to the tender document, within 15 days of the issue of letter of award by the SPA Bhopal. In the event of failure on the part of the successful tenderer to sign the agreement, the earnest money will be forfeited and tender cancelled. In case of works of estimated to cost Rs.15, 00,000/- and above, the successful tenderer shall, upon issue of letter of acceptance of Tender, shall be required to furnish **Performance Guarantee@ 5% of the tendered value in the form of** irrevocable Bank Guarantee of requisite amount to the SPA Bhopal in the Performa annexed to the tender document or **in the form of fixed deposit receipts**, within 15 days of the issue of letter of acceptance of Tender by the SPA Bhopal. In the event of failure on the part of the successful tenderer to furnish the Bank Guarantee within 15 days, the earnest money will be forfeited and tender cancelled.
18. This Notice Inviting Tender shall form a part of the Contract Document. In accordance with clause 1 of the contract, the letter of acceptance shall be issued first in favour of the successful Tenderer/Contractor. After submission of the performance guarantee, the letter of award of work shall be issued. The contract shall be deemed to have come into effect on issue of letter of acceptance of the tender. On the issue of letter of award, the successful Tenderer/Contractor shall, within 15 days from such date, formally sign the agreement consisting of: -
- a) The Notice Inviting Tender, all the documents including additional conditions, specifications and drawings, if any, forming part of the tender, and, as issued at the time of invitation of tender and acceptance thereof together with any correspondence leading thereto.
 - b) Standard "General Conditions of Contract for Civil Works & particular specification, safety code, Model rule for the protection of health & sanitary arrangement for workers, labour regulation, and various other Proforma are available in the offices of the Institute works department of SPA Bhopal.
 - c) Agreement signed on non-judicial stamp paper as per Proforma annexed to the tender document.

19. Payment to the contractors shall be made through e-payment system like ECS & EFT as detailed below: -
- (a) In cities/areas where ECS/EFT facility is provided by Banks, the tenderer must have Account in such ECS/EFT facility providing Banks and that Bank A/c No shall be quoted in the tender by the tenderer.
 - (b) The cost of ECS/EFT will be borne by SPA Bhopal in all cases where the payment to contractor is made in a local Branch i.e. tenderer is having bank account in the same place from where the payment is made by SPA Bhopal.
 - (c) In case payment is made to outside branch i.e. tenderer is having bank account not in the same place from where the payment is made by SPA Bhopal, the crediting cost will have to be borne by the tenderer only.
 - (d) The payments to contractors will compulsorily be made through ECS/EFT in respect of all contracts where the value of the contract is more than Rs. 10 lakhs. First running account bill shall be paid only after
 - (i) Signing of the Agreement/Contract by both the parties, and
 - (ii) Progress chart has been prepared as required under Clause 5 and approved by the competent authority.
20. If a contractor after purchasing the tender does not quote consecutively on three occasions, the contractor may be debarred for further purchase of tenders for a period of six months.
21. The contractor should furnish following details to establish their eligibility and capabilities for the project in Performa given herewith
- (a) Bidder, Qualification and other information: performa-3
 - (b) Declaration: performa-4
 - (c) Bankers authority: performa-5
 - (d) Financial capabilities: performa-6 & 7
 - (e) Letter of financial bid: performa-8
 - (f) Declaration: performa – 9
 - (g) Confirmation letter: performa – 10
 - (h) Agreement: performa – 11
 - (i) Performance Guarantee: performa – 12
 - (j) Affidavit: performa – 13

Dean (P&D)

Institute Works Department

SPA Bhopal

Section -3
General condition of contract-Part-I
&
Section -4
Appendix- Labor laws, Model rules etc.

Please refer at office of the Dean (P & D)

or

CPWD GCC ~ 2014

Section -5
Forms of Bid & Forms of Securities

| S.N. | Particulars | Page no. |
|-------------|---------------------------------|-----------------|
| 01 | Letter of Application | 15 |
| 02 | Letter of submission of bid | 16 |
| 03 | Bidder Information | 18 |
| 04 | Declaration Statement | 21 |
| 05 | Bankers Authority to get status | 22 |
| 06 | Financial Capability-1 | 23 |
| 07 | Financial Capability-2 | 24 |
| 08 | Letter of financial bid | 25 |
| 09 | Declaration | 26 |
| 10 | Confirmation Letter | 27 |
| 11 | Performa for Agreement | 28 |
| 12 | Form of Performance Guarantee | 31 |
| 13 | Affidavit | 33 |

1. Letter of Application

(Letterhead paper of the Bidder)

[Including full postal address, telephone, fax, cable and telex addresses]

[Date]

To,
The Director, SPA BHOPAL,
Neelbad Road, Bhauri, Bhopal (M.P.) – 462030
Phone: 9685092821

Subject: Application to issue Tender form

Sir,

1. Being duly authorized to represent and act on behalf of.....
(Hereinafter “the bidder”), and having reviewed and fully understood all the bid information provided,
the undersigned hereby apply to be qualified by your agency as a bidder for the contract of the
“.....
.....

2. SPA Bhopal and its associates/ representatives are hereby authorized to conduct any inquiries or investigations to verify the statements, documents, and information submitted in connection with this application, and to seek clarification from our bankers and clients regarding any financial and technical aspects. This Letter of Application will also serve as authorization to any individual or authorized representative of any institution, to provide such information deemed necessary to verify statements and information provided in this application or with regard to the resources, experience, and competence of the Bidder.

3. This application is made in the full understanding that:

(a) SPA Bhopal reserves the right, to reject or accept any application, cancel the bidding process and reject all applications; and

(b) SPA Bhopal shall not be liable for any such actions and shall be under no obligation to inform the Bidder of the grounds for them.

4. The undersigned declared that the statements made and the information provided in the duly completed application are complete, true, and correct in every detail.

Authorised Signature
Name and Title of Signatory

2. Letter of Submission of Bid

To,
The Director, SPA BHOPAL,
Neelbad Road, Bhauri, Bhopal (M.P.) – 462030
Phone: 9685092821

Subject: Application to submission of Tender form

Sir,

I/We have read and examined notice inviting tender, specifications applicable, Drawings & Design, Instructions to bidders, General Conditions of Contract, appendix, Special conditions, Schedule of Rate & other documents and Rules referred to in the Conditions of Contract and all other contents in the tender document for the work.

I/We hereby tender for the execution of the work specified for School of Planning and Architecture, Bhopal within the time specified in contract data as per schedule of quantities and in accordance in all respects with the specifications, designs, drawings and instructions in writing referred to General Conditions of the contract and with such materials as are provided for, by and in respect in accordance with, such conditions so far as applicable.

I/We agree to keep the tender open for **30** days from the due date of submission thereof and not to make any modifications in its terms and conditions. If I/We withdraw my/our tender before the said period or issue of letter of acceptance/intent, whichever is earlier, or, makes any modifications in the terms and conditions of the tender which are not acceptable to the SPA Bhopal, then the SPA Bhopal shall, without prejudice to any other right or remedy, be at liberty to forfeit 50% of the said earnest money as aforesaid.

A sum of Rs/(.....) has been deposited in prescribed manner as earnest money. If I/We fail to commence the work specified I/We agree that the said SPA Bhopal shall without prejudice to any other right or remedy, be at liberty to forfeit the said earnest money absolutely otherwise said earnest money shall be retained by competent authority on behalf of the SPA Bhopal towards Security Deposit to execute all the works referred to in the tender documents upon the terms and conditions contained or referred to therein and carry out such deviations as may be ordered, upto maximum of the percentage mentioned in contract data.

I/We hereby intimate that for receiving payments I/we have an account in _____ Bank with account No. _____ Where the ECS / EFT facility of e-payment is available.

I/We hereby declare that I/We shall treat the tender documents drawings and other records connected with the work as secret/confidential documents and shall not communicate information derived therefrom to any person other than a person to whom I/We am/are authorized to communicate the same or use the information in any manner prejudicial to the safety of the State.

I/We agree that should I/We fail to commence the work specified in the above memorandum, an amount equal to the amount of the earnest money mentioned in the form of invitation of tender shall be absolutely forfeited to the SPA Bhopal and the same may at the option of the competent authority on behalf of the SPA Bhopal be recovered without prejudice to any right or remedy available in law out of

the deposit in so far as the same may extend in terms of the said bond and in the event of deficiency out of any other money due to me/us under this contract or otherwise.

I/We agree that this contract is subject to jurisdiction of court at Bhopal, M.P. only.

Dated.....

| | |
|-------------|-------------------------|
| Witness: | () |
| Address: | Signature of Contractor |
| Occupation: | Postal Address: - |

A C C E P T A N C E

The above tender (as modified by you (Contractor) and as provided in the letters mentioned hereunder) is accepted by me for and on behalf of the SPA Bhopal for a sum of Rs._____

(Rupees_____

_____) the letters referred to below shall form part of this Contract Agreement:-

- (a)
- (b)
- (c)

Dean (P & D)
 Institute Works Department
 SPA Bhopal

3. Bidder, Qualification and other information

Notes on Form of Qualification Information

The information to be filled in by bidders in the following pages will be used for purposes of post-qualification as provided for in Clause 4 of the Instructions to Bidders. This information will not be incorporated in the Contract. Attach additional pages as necessary.

1. Individual Bidders

1.1 Constitution or legal status of Bidder: (Attach copy)

(a) Place of registration:

(b) Principal place of business:

(c) Power of attorney of signatory of Bid

1.2 Total annual volume of civil engineering construction work executed and payments received in the last five years proceeding the year in which bids are invited.

(Attach certificate from Chartered Accountant)

| S.N. | Financial Year | Amount (In Lakhs) |
|------|----------------|-------------------|
| 01 | 2014-15 | |
| 02 | 2013-14 | |
| 03 | 2012-13 | |
| 04 | 2011-12 | |
| 05 | 2010-11 | |

1.3 Work performed as prime Contractor (in the same name and style) on construction works of a similar nature and volume over the last five years. *(Attach certificate from the Engineer-in-charge)*

| S.N. | | Project-1 | Project-2 | Project-3 | Project-4 |
|------|-------------------------------|-----------|-----------|-----------|-----------|
| 01 | Project Name | | | | |
| 02 | Name of Employer | | | | |
| 03 | Description of work order | | | | |
| 04 | Value of contract | | | | |
| 05 | Contract No. | | | | |
| 06 | Date of Issue of Work | | | | |
| 07 | Stipulated Date of Completion | | | | |
| 08 | Actual Date of Completion | | | | |
| 09 | Remarks for Delay, if any | | | | |

1.3.1 Information on Bid Capacity (works for which bids have been submitted and works which are yet to be completed) as on the date of this bid.

1.4 Existing commitments and on-going construction works:

| S.N. | | Project-1 | Project-2 | Project-3 | Project-4 |
|------|---|-----------|-----------|-----------|-----------|
| 01 | Description of Work | | | | |
| 02 | Place & State | | | | |
| 03 | Contract No & Date | | | | |
| 04 | Name & Address of Employer | | | | |
| 05 | Value of Contract (Rs. In lakhs) | | | | |
| 06 | Stipulated period of completion | | | | |
| 07 | Value of works remaining to be completed (Rs. Lakhs)* | | | | |
| 08 | Anticipated Date of completion | | | | |
| 09 | Remarks for Delay, if any | | | | |

* Enclose certificate(s) from Engineer(s)-in-charge for value of work remaining to be completed.

1.5 Works for which bids already submitted:

| S.N. | | Project-1 | Project-2 | Project-3 | Project-4 |
|------|---------------------------------|-----------|-----------|-----------|-----------|
| 01 | Description of Work | | | | |
| 02 | Place & State | | | | |
| 03 | Name & Address of Employer | | | | |
| 04 | Value of work (Rs. In lakhs) | | | | |
| 05 | Stipulated period of completion | | | | |
| 06 | Date when decision is expected | | | | |
| 07 | Remarks for Delay, if any | | | | |

1.6 Availability of Major items of Contractor's Equipment proposed for carrying out the Works. List all information requested below. Refer also to Clause 4.2(d) and Clause 4.4 b (b) of the Instructions to Bidders.

| S.N. | Item of Equipment | Description, make, and age (Years), and capacity | Condition (new, good, poor) and number available | Owned, leased (from whom?), or to be purchased |
|------|-------------------|--|--|--|
| 01 | | | | |
| 02 | | | | |
| 03 | | | | |
| 04 | | | | |
| 05 | | | | |
| 06 | | | | |
| 07 | | | | |

1.7 Qualifications of technical personnel proposed for the Contract. Refer also to Clause 4.2(e) of the Instructions to Bidders and Clause 9.1 of Part-1 General Conditions of Contract.

| S.N. | Name of employee | Post held | Qualification | Experience | |
|------|------------------|-----------|---------------|------------|----------------|
| | | | | Road works | Building works |
| 01 | | | | | |
| 02 | | | | | |
| 03 | | | | | |

1.8 Proposed sub-contractors and firms involved for construction. Refer to Clause 7 of Part I General Conditions of Contract.

| S.N. | Sections of the Works | Value of subcontract | Sub-contractor(name and address) | Experience in similar work |
|------|-----------------------|----------------------|----------------------------------|----------------------------|
| 01 | | | | |
| 02 | | | | |

Note: The capability of the sub-Contractor will also be assessed (on the same lines as for the main Contractor) before according approval to him.

1.9 Financial reports for the last five years: balance sheets, profit and loss statements, auditors' reports, etc. List below and attach copies.

(A)

(B)

1.10 Evidence of access to financial resources to meet the qualification requirements: cash in hand, lines of credit, etc. List below and attach copies of support documents. (Sample format attached).

(A)

(B)

1.11 Name, address, and telephone, telex, and facsimile numbers of banks that may provide references if contacted by the Employer.

(A)

(B)

1.12 Information on current litigation in which the Bidder is involved.

| S.N. | Name of Other party(s) | Cause of dispute | Litigation where (Court/arbitration) | Amount involved |
|------|------------------------|------------------|--------------------------------------|-----------------|
| 01 | | | | |
| 02 | | | | |

1.11 Proposed Programme (work method and schedule). Descriptions, drawings, and charts as necessary, to comply with the requirements of the bidding documents.

4. Declaration Statement

(Letterhead paper of the Bidder)

[date]

To,
The Director, SPA BHOPAL,
Neelbad Road, Bhauri, Bhopal (M.P.) – 462030
Phone: 9685092821

Dear Sir:

1. I, the undersigned, do hereby certify that all the statements made in the application and attachments thereto are true and correct.
2. The undersigned also hereby certifies that neither our firms M/s..... nor any of its constituent partners have abandoned any work awarded to us by any Agency in India nor any contract awarded to us for such works has been rescinded, during last five years prior to the date of this application.
3. The undersigned also furnish undertaking that we are not declared by any court of law as proclaimed offenders also that we are not convicted under any law for the offences punishable under Indian Penal Code, Negotiable Instrument Act of any Labour/ employee beneficial legislations.
4. The undersigned hereby authorize(s) and request(s) any bank, person, firm or corporation to furnish pertinent information deemed necessary and requested by to verify this statement or regarding my (our) competence and general reputation.
5. The undersigned understands and agrees that further qualifying information may be requested, and agrees to furnish any such information at the request of the SPA Bhopal

Signed by an Authorised Officer of the Firm

Title of Officer

Name of Firm

Date

**5. SPECIMEN FORMAT FROM BIDDER TO BANKERS AUTHORISING THEM TO PROVIDE
INFORMATION TO SPA BHOPAL / ITS REPRESENTATIVES**

To

Name of Bank/ Address/ city

Dear Sir:

We have recently submitted a Bid Proposals to School of Planning and Architecture Bhopal, for implementing its project for _____.

We hereby authorize you to provide all information/ data readily about us and our credit status, as may be desired by SPA Bhopal and you need not seek any clearance/ opinion from us for providing the information/ data to SPA Bhopal.

Sincerely,
Authorised Signatory

6. Financial Capability-1

Name of Bidder:-

Bidder should provide financial information to demonstrate that they meet the requirements stated in the Instructions to Bidders. Each Bidder shall complete this form. If necessary, use separate sheets to provide complete banker information. A copy of the audited balance sheets should be attached. Autonomous construction subdivisions of parent conglomerate business shall submit financial information related only to the particular activities of the subdivision.

1. Name of Banker
2. Address of Banker
3. Telephone Contract name and title
4. Tax E-mail

Summarize actual assets and liabilities for the previous five years.

| S.N. | Financial Information in Indian Rupees | Actual: Previous Five years. | | | | |
|------|--|------------------------------|---|---|---|---|
| | | 5 | 4 | 3 | 2 | 1 |
| 01 | Total assets | | | | | |
| 02 | Current assets | | | | | |
| 03 | Total Liabilities | | | | | |
| 04 | Net Worth | | | | | |
| 05 | Working Capital | | | | | |
| 06 | Current Liabilities | | | | | |
| 07 | Profits before taxes | | | | | |
| 08 | Profits after taxes | | | | | |

Specify proposed sources of financing such as liquid assets, unencumbered real estates, lines of credit and other financial means, net of current commitments, available to meet the total construction cash flow demands of the subject contract or contracts as indicated in Instructions to Bidders _____.

| S.N. | Source of finance | Amount |
|------|-------------------|--------|
| | | |
| | | |
| | | |

Attach audited financial statements for the last five years (for the individual Bidder or each partner of a joint venture).

Note: (1) For previous five year, year 1= 2014-2015, year 2= 2013-2014 etc.

7. Financial Capability-2

Name of Bidder:-

Bidder should provide financial information to demonstrate that they meet the requirements stated in the Instructions to Bidders. Each Bidder shall complete this form. If necessary, use separate sheets to provide complete banker information. A copy of the audited balance sheets should be attached. Autonomous construction subdivisions of parent conglomerate business shall submit financial information related only to the particular activities of the subdivision.

1. Name of Banker
2. Address of Banker
3. Telephone Contract name and title
4. Tax E-mail

** If more than one banker is proposing to finance the project(s), the details in the above format may be appendix on all bidders*

The Details of financial capability (as indicated in Clause 5.1 of Instructions to Bidders) is as under

| <i>S.N.</i> | <i>Source of finance</i> | <i>Amount</i> |
|-------------|--|---------------|
| <i>01</i> | Net working capital | |
| <i>02</i> | Lines of credit from Banks (Bank Certificate enclosed) | |
| <i>03</i> | Other financial means | |
| <i>04</i> | Own Resources | |
| <i>05</i> | Available money guarantees (name and address of banks given) | |
| <i>A</i> | Total of A | |
| <i>01</i> | Liability during next 3 years | |
| <i>03</i> | Financial Commitments for ongoing civil works | |
| <i>03</i> | Other commitments | |
| <i>B</i> | Total of B | |

Note: All the above items shall be supported by specific details/list of items/certified balance sheet

8. Letter of financial bid*(Letterhead of the Bidder)*

Ref. no.

[date]

To,

The Director, SPA BHOPAL,**Neelbad Road, Bhauri, Bhopal (M.P.) – 462030****Phone: 9685092821****Subject: “Construction of foot ball ground with stage for SPA Bhopal at Bhauri, Bhopal (M.P.)”.**

Dear Sir:

1.0 Having examined the Bid Document including Notice Inviting Bids, Instructions to Bidders, General Conditions of Contract, Special Conditions of Contract, Technical Specifications, Bill of Quantities, Drawings, Schedules and Annexure for the execution of the above named works, we, the undersigned, offer to execute and complete such works and remedy any defects therein in conformity with the said Bid Document at the prices indicated in Schedule 1 to this letter.

2.0 Our financial bid for the execution of the above said project as per bill of quantity, drawings and specifications attached herewith will be. _____ (In Words: _____ only) Including of all taxes and duties applicable.

3.0 We undertake, if our Bid is accepted, to commence the works within fourteen (14) days of receipt of the Engineer’s order to commence, and to complete and deliver the sections and whole of the works comprised in the Contract within the specified period. We also undertake to furnish Performance Security (ie) in the form of a Bank Guarantee in accordance with the Conditions of Contract.

4.0 We agree to abide by this Bid for the period of thirty days (30 days) from the date of Bid opening and it shall remain binding upon us and may be accepted at any time before the expiry of that period.

5.0 We confirm our agreement to treat the Bid Document, Drawings and other records connected with the works as secret and confidential document and shall not communicate information contained therein to any other person other than the person authorized by Employer or use such information in any manner prejudicial to the safety and integrity of the works.

6.0 We undertake that, in completing for (and, if the award is made to us, in executing) the above Contract, we will observe the laws against fraud and corruption in force in India namely “Prevention of Corruption Act 1988”. We confirm that our firm has valid VAT/PAN registrations along with EPF, ESI codes as stipulated.

7.0 We hereby confirm that this Bid complies with the Eligibility, Bid validity and Bid security required as stated in the Bidding documents.

Name of Bidder with official seal
Address:

Yours faithfully,
Authorised Signature:
Name and Title of Signatory:

9. Declaration

(Letterhead of the Bidder)

Ref. no.

[date]

To,

The Director, SPA BHOPAL,

Neelbad Road, Bhauri, Bhopal (M.P.) – 462030

Phone: 9685092821

Subject: “Construction of foot ball ground with stage for SPA Bhopal at Bhauri, Bhopal (M.P.)”.

Dear Sir:

It is to certify that:-

- 1) I / we have submitted the tenders in the Proforma as downloaded directly from the website. &there is no change in formatting, number of pages etc.
- 2) I / We have submitted tender documents which are same / identical as available in the Website.
- 3) I / we have not made any corrections / additions / alteration / omission etc in the tender documents downloaded from web by me / us.
- 4) I / We have checked that no page is missing and all pages as per the index are available & that all pages of Tender document submitted by us are clear & legible.
- 5) I / we have signed (with stamp) all the pages of the tender document before submitting the same.
- 6) I / we have sealed the tender documents properly before submitting the same.
- 7) I / We have submitted the cost of tender along with the EMD.
- 8) I / we have read carefully & understood the important instructions to the tenderers who have down loaded the tenders from the web.
- 9) In case at any later stage, it is found that there is difference in our downloaded tender documents from the Original, SPA, Bhopal shall have the absolute right to take any action as deemed fit without any prior intimation to Me / Us.
- 10) In case at any later stage, it is found that there is difference in our downloaded tender documents from the Original, the tender / work will be cancelled and Earnest Money / Security Deposit will be forfeited at any stage whenever it is so noticed. The department will not pay any damages to me / us on this account.
- 11) In case at any later stage, it is found there is difference in our downloaded tender documents from the Original, I / We may also be debarred for further participation in the tenders for SPA. Bhopal & would also render me / us liable to be removed from the approved list of contractors of the Department.

Name of Bidder with official seal
Address:

Yours faithfully,
Authorised Signature:
Name and Title of Signatory:

10. Confirmation Letter

(Letterhead of the Bidder)

Ref. no.

[Date]

To,
The Director, SPA BHOPAL,
Neelbad Road, Bhauri, Bhopal (M.P.) – 462030
Phone: 9685092821

Subject: “Construction of foot ball ground with stage for SPA Bhopal at Bhauri, Bhopal (M.P.)”.

DEAR SIR,

We acknowledge receipt of your letter of Intent, ref..... Dated..... and unconditionally accept the offer to take up above captioned works at the price indicated in the letter of intent.

We also confirm our acceptance to all the corrections and modifications made by the Employer in respect of our bid.

We undertake to provide you unconditional bank guarantee towards performance security and additional security for unbalanced bid as per the agreed format within the prescribed data as per the Instructions to Bidder and Conditions of Contract.

Yours faithfully,

Authorized Signature:

Name and Title of Signatory:

Name of Agency:

11. PROFORMA FOR AGREEMENT**(ON NON-JUDICIAL STAMP PAPER OF APPROPRIATE VALUE)**

CONTRACT AGREEMENT FOR THE WORK OF -----DATED-----
 Between M/s----- (refer note) in the town of
 _____hereinafter called the contractor (which term shall unless excluded by or repugnant to
 be subject or context include its successors and permitted assigns) of the one part and the School of
 Planning and Architecture, Bhopal hereinafter called the SPA Bhopal (which term shall unless excluded
 by or repugnant to the subject or context include its successes and assigns) of the other part.

WHEREAS

a. The SPA Bhopal is desirous that the construction of _____ at
 _____ should be executed as mentioned, enumerated or referred to in the tender including Press
 Notice Inviting Tender, General Conditions of the Contract, Special Conditions of the Contract,
 Specifications, Drawings, Plans, Time Schedule of completion of jobs, Schedule of Quantities and Rates,
 Agreed Variations, other documents, has called for Tender.

b. The contractor has inspected the site and surroundings of the work specified in the tender documents
 and has satisfied himself by carefully examination before submitting his tender as to the nature of the
 surface, strata, soil, sub-soil and grounds, the form and nature of the site and local conditions the
 quantities, nature and magnitude of the work the availability of labour and materials necessary for the
 execution of work, the means of access to site, the supply of power and water thereto and the
 accommodation he may require and has made local and independent enquiries and obtained complete
 information as to the matters and things referred to or implied in the tender documents or having any
 connection therewith, and has considered the nature and extent of all the probable and possible
 situations, delays, hindrances or interferences to or with the execution and completion of the work to
 be carried out under the contract, and has examined and considered all other matters, conditions and
 things and probable and possible contingencies, and generally all matters incidental thereto and
 ancillary thereof affecting the execution and completion of the work and which might have influenced
 him in making his tender.

c. The tender documents including the SPA BHOPAL's Press Notice Inviting Tender, General conditions
 of contract, Special Conditions of Contract, Schedule of Quantities and rates, General obligations,
 Specifications, Drawings, plan, time schedule for completiOn of work. Letter of Acceptance of tender
 and any statement of agreed variations with its enclosures copies of which are hereto annexed form
 part of this contract though separately set out herein and are included in the expression Contract
 wherever herein used.

AND WHEREAS

The SPA Bhopal accepted the tender of M/s ----- (refer note-----)
 (Contractor) for the construction of ----- at -----
 and conveyed vide letter No.-----dated -----at the rates stated in the
 Schedule of quantities for the work and accepted by the SPA BHOPAL (hereinafter called the Schedule
 of Rates) upon the terms and subject to the conditions of the contract.

NOW THIS AGREEMENT WITNESSTH & IT IS HEREBY AGREED AND DECLARED AS FOLLOWS.

1. In consideration of the payment to be made to the contract for the work to be executed by him, the contractor hereby convenient with the SPA BHOPAL that the contractor shall and will duly provide, execute, complete and maintain the said work and shall do and perform all other acts and things in the contract mentioned or described or which are to be implied and there-from or may be reasonably necessary for the completion of the said works and at the said times and in the manner and subject to the terms and conditions or stipulations mentioned in the contract, AND

2. In consideration of the due provisions execution, completion and maintenance of the said work, the SPA BHOPAL does hereby agree with the contractor that the SPA BHOPAL will pay to contractor the respective amounts for the work actually done by him and approved by the SPA BHOPAL at the Schedule or Rates and such other sum payable to the contractor under provision of the contract, such payment to be made at such time in such manner as prescribed for in the contract.

3. The contract is subjected to jurisdiction of court at Madhya Pradesh only. It is specifically and distinctly understood and agreed between the SPA BHOPAL and the contractor that the contractor shall have no right, title or interest in the site made available by the SPA BHOPAL for execution of the works or in the building, structures or works executed on the said site by the contractor or in the goods, articles, materials, etc. brought on the said site (unless the same specifically belongs to the contractor) and the contractor shall not have or deemed to have any lien whatsoever charge for unpaid bills will not be entitled to assume or retain possession or control of the site or structures and the SPA BHOPAL shall have an absolute and unfettered right to take full possession of site and to remove the contractor, their servants, agents and materials belonging to the contractor and lying on the site.

In Witness whereof the parties hereto have here-into set their respective hands and seals in the day and the year first above written.

Signed and delivered for and on behalf of
SPA BHOPAL
OFFICIAL ADDRESS

Signature and delivered for and on
behalf of the contractor

(Contractor)

Date

Date

Place

Place

IN PRESENCE OF TWO WITNESSES

SIGNATURE

SIGNATURE

NAME

NAME

SIGNATURE

SIGNATURE

NAME

NAME

For Proprietary Concern

Shri.....s/o.....r/o.....carrying on business under the name and style of.....at..... (Hereinafter called the said Contractor which expression shall unless the context requires otherwise include his heirs, executors, administrators and legal representatives).

For Partnership Concern

M/sa partnership firm having its registered office at(hereinafter called the said Contractor which expression shall unless the context requires otherwise include his heirs, executors, administrators and legal representatives). The partners of the firms are:

- i) Shris/o....., And
- i) Shris/o.....etc.

For Companies

M/sa company duly incorporated under the Indian Companies Act, 1956 and having its registered office atin the state of(hereinafter called the said Contractor which expression shall unless the context requires otherwise include its successors and assign).

12. FORM OF PERFORMANCE SECURITY**BANK GUARANTEE BOND**

1. In consideration of the SPA BHOPAL (hereinafter called “the SPA BHOPAL”) having agreed under the terms and conditions of agreement No. _____ Dated _____ made between _____ and _____ (hereinafter called “the said contractor(s)”) for the _____ work (hereinafter called “the said agreement”) for compliance of his obligation in accordance with the terms and conditions in the said agreement.

We _____ (indicate the name of the Bank) (hereinafter referred to as “as Bank) hereby undertake to pay to the SPA BHOPAL and amount not exceeding Rs. _____ (Rupees _____ only) on demand by the SPA BHOPAL.

2. We _____ (Indicate the name of the Bank) do hereby undertake to pay the amount due and payable under this Guarantee without any demure, merely on a demand from the SPA BHOPAL stating that the amount claimed is required to meet the recoveries due or likely to be due from the said contractor(s). Any such demand made on the Bank shall be conclusive as regards the amount due and payable by the bank under this Guarantee. However, our liability under this guarantee shall be restricted to an amount not exceeding Rs. _____ (Rupees _____ only).

3. We undertake to pay to the SPA BHOPAL any money so demanded notwithstanding any dispute or disputes raised by the contractor (s) in any suit or proceeding pending before any court or Tribunal relating thereto our liability under this present being absolute and unequivocal. The payment made by us under this bond shall be valid discharge of our liability for payment to there-under and the contractor(s) shall have no claim against us making such payment.

4. We _____ (Indicate the name of Bank) further agree that the guarantee herein contained shall remain in full force and effect during the period that would be taken for the performance of the said agreement and that it shall continue to be enforceable till all the dues of the SPA BHOPAL under or by virtue of the said agreement have been fully paid and it is claims satisfied or discharged or till Engineer-in-charge on behalf of the SPA BHOPAL certifies that the terms and conditions of the said Agreement have been fully and properly carried out by the said contractor(s) accordingly discharges this guarantee.

5. We _____ (indicate the name of Bank) further agree with the SPA BHOPAL that the SPA BHOPAL shall have the fullest liberty without our consent and without affecting any manner our obligations hereunder to vary any of the terms and conditions of the said agreement or to extend time of performance by the said contractor(s) from time to time or to postpone for any time to time any of the powers exercisable by the SPA BHOPAL against the said contractor(s) and to forebear or enforce any of the terms and conditions relating to the said agreement shall not be relieved from our liability by reasons of any such variation or extension being granted to the said contractor(s) or for any forbearance act of omission on that part of the SPA BHOPAL or any indulgence by the SPA BHOPAL to

the said contractor(s) or by any such matter or thing whatsoever which under the law relating to sureties would, but for this provision, have effected or so relieving us.

6. The guarantee will not be discharged due to the change in the constitution of the Bank or the contractor(s).

7. We _____ (indicate the name of Bank) lastly undertake not to revoke this guarantee except with the previous consent of the SPA BHOPAL in writing.

8. This guarantee shall be valid upto _____ unless extended on demand by SPA BHOPAL. Notwithstanding any thing mentioned above our liability against this Guarantee is restricted to Rs. _____ (Rs. _____ only) and unless a claim in writing is lodged with us within six months of the date of expiry or the extended date of expiry of this guarantee, all our liabilities under the Guarantee shall stand discharged.

Date the _____ date of _____

For _____

(Indicate the name of Bank)

13. AFFIDAVIT

I/We have submitted a bank guarantee for the work _____
_____ (Name of Work), Agreement No. _____

Dated: _____ from _____ (Name of the
Division) with a view to seek exemption from payment of performance guarantee in cash. This Bank
guarantee expires on _____

I/ We undertake to keep the validity of the bank guarantee intact by getting it extended from time to
time at my/our own initiative upto a period of _____ months after the
recorded date of completion of the work or as directed by the Engineer in charge. I/We also indemnify
the School of Planning and Architecture, Bhopal against any losses arising out of non encashment of the
bank guarantee if any.

(Deponent)

Signature of Contractor

Note: The affidavit is to be given by the Executants before a first class Magistrate.

Section-6**Bill of Quantities for works (BOQ)****A. A. Preamble**

1. The Bill of Quantities shall be read in conjunction with the Instruction to Bidders, General and Special Conditions of Contract, Technical Specifications and Drawings.
2. The quantities given in the Bill of Quantities are approximate and provisional, which are given to provide a common basis for making payment for works. Actual quantities of work are likely to increase or decrease as per the requirement at site. Hence there is no claim for any additional or less quantities than the specified in the BOQ.
3. The rates in the Bill of Quantities shall, except insofar as it is otherwise provided under the Contract, include all construction plant, labour, supervision, materials, erection, transportation, maintenance, insurance, administrative overheads, profit, taxes and duties, together with all general risks, liabilities and obligations set out or implied in the Contract.
4. The Bidder shall indicate the unit rate and line total on the Total Estimate Bid Amount, which shall be applicable on each item of the Bill of Quantities, whether quantities are stated or not.
5. General directions and description of work and materials are not necessarily repeated nor summarized in the Bill of Quantities. The whole cost of complying with the provisions of the Contract shall be included in the items provided in the Bill of Quantities. References to the relevant sections of the contract documentation shall be made before entering prices against each item in the Bill of Quantities.

SPA Bhopal,

| S.No | Description | Quantity | Unit | Rate | Amount |
|------|---|----------|------|------|--------|
| | EARTH WORK | | | | |
| 1 | 2.8 Earth work in excavation by mechanical means (Hydraulic excavator) / manual means in foundation trenches or drains (not exceeding 1.5 m in width or 10 sqm on plan), including dressing of sides and ramming of bottoms, lift upto 1.5 m, including getting out the excavated soil and disposal of surplus excavated soil as directed, within a lead of 50 m. 2.8.1 All kinds of soil. | 400 | cum | | |
| 2 | Excavation of B.C.SOIL Removal of Black cotton soil up to desired depth above Natural Ground Level(N. G. L.) and dumping the same at the designated locations within the site premises with lead up to 1000 meters. including excavation, Loading, Unloading, & spreading of material in layer wise depth up to 200 mm & mixed with water at OMC and then compacted by vibratory roller so as to achieve minimum dry density. | 2000 | cum | | |
| 3 | 2.7 Earth work in excavation by mechanical means (Hydraulic excavator) / manual means over areas (exceeding 30 cm in depth, 1.5 m in width as well as 10 sqm on plan) including disposal of excavated earth, lead upto 50 m and lift upto 1.5 m, disposed earth to be levelled and neatly dressed. 2.7.1 Ordinary rock | 300 | cum | | |
| 4 | Filling available excavated earth (excluding rock) in trenches, plinth, sides of foundations etc. in layers not exceeding 20cm in depth, consolidating each deposited layer by ramming and watering, lead up to 50 m and lift upto 1.5 m | 350 | cum | | |
| 5 | Supplying and filling in plinth with stone dust under floors including, watering, ramming consolidating and dressing complete. | 65 | cum | | |
| | CONCRETE WORK | | | | |
| 6 | Providing and laying in position cement concrete of specified grade excluding the cost of centring and shuttering - All work upto plinth level : | | | | |

| | | | | | |
|-----------|---|-----|-------|--|--|
| 6.1 | 1:3:6 (1 Cement :3 coarse sand : 6graded stone aggregate20 mm nominal size). | 150 | cum | | |
| 7 | Providing and laying damp-proof course 50mm thick with cement concrete 1:2:4 (1 cement : 2 coarse sand : 4 graded stone aggregate 20mm nominal size). | 300 | Sqm | | |
| 8 | Brick work with Fly ash modular brick of class designation 50 in foundation and plinth in: | | | | |
| 8.1 | Cement mortar 1:6 (1 cement : 6 coarse sand) | 60 | Cum | | |
| | STONE WORK | | | | |
| 9 | Random rubble masonry with hard stone in foundation and plinth including levelling up with cement concrete 1:6:12 (1 cement : 6 coarse sand : 12 graded stone aggregate 20mm nominal size) at plinth level with : | | | | |
| 9.1 | Cement mortar 1:6 (1 cement : 6 coarse sand) | 240 | Cum | | |
| 10 | FLOORING | | | | |
| 10 | 11.28 40 mm thick fine dressed stone flooring over 20 mm (average) thick base of cement mortar 1:5 (1cement : 5 coarse sand) with joints finished flush. | | | | |
| 10.1 | Red sand stone | 130 | Sqm | | |
| 10.2 | White sand stone | 90 | Sqm | | |
| 11 | Extra for pre finished nosing in treads of steps of Kota stone/ sand stone slab | 225 | meter | | |
| 12 | 11.26 Kota stone slab flooring over 20 mm (average) thick base laid over and jointed with grey cement slurry mixed with pigment to match the shade of the slab, including rubbing and polishing complete with base of cement mortar 1 : 4 (1 cement : 4 coarse sand) : 11.26.1 25 mm thick. | 220 | Sqm | | |
| 13 | 11.27 Kota stone slabs 20 mm thick in risers of steps, skirting, dado and pillars laid on 12 mm (average) thick cement mortar 1:3 (1 cement: 3 coarse sand) and jointed with grey cement slurry mixed with pigment to match the shade of the slabs, including rubbing and polishing complete. | 35 | Sqm | | |

| FINISHING | | | | | |
|------------------|---|-------|-------|--|--|
| 14 | 12 mm cement plaster of mix : | | | | |
| 14.1 | 1:6 (1 cement : 6 fine sand) | 175 | Sqm | | |
| 15 | 10.25 Steel work welded in built up sections/ framed work, including cutting, hoisting, fixing in position and applying a priming coat of approved steel primer using structural steel etc. as required.10.25.2 In gratings, frames, guard bar, ladder, railings, brackets, gates and similar works | 13500 | Kg | | |
| 16 | Providing and fixing on wall face Unplasticised Rigid PVC rain water pipes conforming to IS : 13592 Type A including jointing with seal ring conforming to IS : 5382 leaving 10 mm gap for thermal expansion. (i) Single socketed pipes | | | | |
| 16.1 | 110 mm diameter | 150 | meter | | |
| 17 | 13.9 Providing weep holes in Brick masonry/Plain/ Reinforced concrete abutment, wing wall/return wall with 100 mm dia AC/PVC pipe, extending through the full width of the structure with slope of 1V :20H towards drawing face. Complete as per drawing and Technical specifications | 100 | metre | | |
| 18 | Providing and fixing on wall face Unplasticised - PVC moulded fittings/ accessories for Unplasticised Rigid PVC rain water pipes conforming to IS : 13592 Type A including jointing with seal ring conforming to IS : 5382 leaving 10 mm gap for thermal expansion. | | | | |
| 18.1 | Bend 87.5° | | | | |
| 18.1.1 | 110 mm bend | 15 | Each | | |
| 19 | Finishing walls with Acrylic Smooth exterior paint of required shade : New work (Two or more coat applied @ 1.67 ltr/10 sqm over and including priming coat of exterior primer applied @ 2.20 kg/ 10 sqm) | 175 | Sqm | | |
| 20 | 13.61 Painting with synthetic enamel paint of approved brand and manufacture to give an even shade : 13.61.1 Two or more coats on new work | 250 | Sqm | | |

| | | | | | |
|------|---|-----|-------|--|--|
| 21 | Providing & laying below ground PERFORATED unplasticised PVC Pipe to withstand working pressure of 4kg/cm ² solid waste pipe confirming to IS 13592 & IS 4985 including jointing with seal ring confirming to IS 5282 leaving 10 mm gap for thermal expansion all necessary fitting etc complete. excavation to be paid separately.200 mm diameter OD. (pipe laying with Narrow Filter Sub- Surface Drain) | 100 | RM | | |
| 22 | 7.2 Narrow Filter Sub- Surface Drain Construction of a narrow filter sub- surface drain consisting of porous or perforated pipe laid in narrow trench surrounded by a geotextile filter fabric, with a minimum of 450 mm overlap of fabric and installed as per clause 702.3 and 309.3.5 including excavation and backfilling. | 100 | metre | | |
| 23 | Providing and laying factory made coloured chamfered edge CementConcrete paver blocks of required strength, thickness & size/shape, made by table vibratory method using PU mould, laid in required colour & patternover 50mm thick compacted bed of fine sand, compacting and properembedding/laying of inter locking paver blocks into the sand bedding layerthrough vibratory compaction by using plate vibrator, filling the joints withjamuna sand and cutting of paver blocks as per required size and pattern,finishing and sweeping extra sand in footpath, parks, lawns, drive ways orlight traffic parking etc. complete as per manufacturer's specifications &direction of Engineerin-Charge. 60mm thick C.C. paver block of M-35grade with approved colour, design & pattern. | 950 | Sqm | | |
| 24 | 5.9 Centering and shuttering including strutting, propping etc. and removal of form for : | | | | |
| 24.1 | 5.9.1 Foundations, footings, bases of columns, etc. for mass concrete. | 325 | Sqm | | |
| 24.2 | 5.9.2 Walls (any thickness) including attached pilasters, butteresses,plinth and string courses etc. | 800 | Sqm | | |
| 25 | 5.1 Providing and laying in position specified grade of reinforced cement concrete, excluding the cost of centering, shuttering, finishing and reinforcement - All work up to plinth level : | | | | |

| | | | | | |
|------|--|------|-------|--|--|
| 25.1 | 5.1.2 1:1.5:3 (1 cement : 1.5 coarse sand : 3 graded stone aggregate 20 mm nominal size) | 90 | Cum | | |
| 26 | 5.22 Steel reinforcement for R.C.C. work including straightening, cutting, bending, placing in position and binding all complete upto plinth level | | | | |
| 26.1 | 5.22.6 Thermo-Mechanically Treated bars. | 7500 | Kg | | |
| 27 | 19.6 Providing and laying non-pressure NP2 class (light duty) R.C.C. pipes with collars jointed with stiff mixture of cement mortar in the proportion of 1:2 (1 cement : 2 fine sand) including testing of joints etc. complete : 19.6.4 300 mm dia. R.C.C. pipe | 30 | metre | | |
| 27.1 | 19.6.3 250 mm dia. R.C.C. pipe | 245 | metre | | |
| 28 | 10.28 Providing and fixing stainless steel (Grade 304) railing made of Hollow tubes, channels, plates etc., including welding, grinding, buffing, polishing and making curvature (wherever required) and fitting the same with necessary stainless steel nuts and bolts complete, i/c fixing the railing with necessary accessories & stainless steel dash fasteners , stainless steel bolts etc., of required size, on the top of the floor or the side of waist slab with suitable arrangement as per approval of Engineer-in-charge, for payment purpose only weight of stainless steel members shall be considered excluding fixing accessories such as nuts, bolts, fasteners etc.). | 110 | Kg | | |
| 29 | Excavation of serviceable soil using Hydraulic Excavator and Tippers with disposal upto 1000 metres. Excavation of Earth work in all kind of soil with hydraulic excavator including cutting and loading in tippers, trimming bottom and side slopes, in accordance with requirements of lines, grades and cross sections, and transporting to the embankment location with all lifts and lead up to 1000m as per relevent clauses of section-300 of specification. | 4500 | Cum | | |
| | Construction of Embankment with Material Obtained from GROUND Cutting | | | | |

| | | | | | |
|------|---|------|-----|--|--|
| 30 | Construction of embankment with approved materials deposited at site from Ground cutting and excavation from drain and foundation of other structures or from borrow area graded and compacted using vibratory rollers of 80 to 100 kN static weight to meet requirement of Tables 300.1 and 300.2 as per Technical Specification Clauses 301.4 & 301.5 including, watering rolling etc complete. | 2200 | Cum | | |
| 31 | Embankment Construction with Material Obtained from Borrow Pits : Construction of embankment with approved material having CBR>7 obtained from borrow pits with all lifts and leads, transporting to site, spreading, grading to required slope and compacting to meet requirement of table 300-1, 300-2 and as per relevant clauses of section-300. Note: using vibratory rollers of 80 to 100 kN & Motor grader shall be used compulsory. | 1100 | Cum | | |
| 32 | Construction of granular sub-base by providing well graded material having CBR >= 20, spreading in uniform layers with motor grader on prepared surface, mixing by mix in place method with rotavator at OMC, and compacting with vibratory rollers of 80 to 100 kN static weight to achieve the desired density, complete as per Technical Specification Clause 401 for gradings-1' mentioned in table 400.1 Note : Vibratory road roller & motor grader shall be used compulsory. | | | | |
| 32.1 | (A)Crushed stone materials | 1160 | Cum | | |
| 33 | Gravel/Soil-Aggregate Base (Table 400.2) Grading A Construction of gravel/soil-aggregate base of CBR> 80 by providing well graded material, spreading in uniform layers with motor grader on prepared surface, mixing by mix in place method with rotavator at OMC, and compacting with vibratory roller of 80- 100 kN static weight to achieve the desired density, complete as per Technical Specifications Clause 402 Note : The compacted thickness for a layer with Grading A . | 725 | Cum | | |

| | | | | | |
|-------------------|--|------|--------|--|--|
| 34 | Supplying, Laying and compacting of good earth [Non-Cohesive soil] and mixing of manure at top surface with earth for grassing at site with all leads & lifts. and mixed with water at OMC and then compacted by vibratory roller so as to achieve minimum dry density. Note: Good earth as required as per direction of Officer-in-charge | 1325 | Cum | | |
| 35 | 23.10 Grassing with selection No.1 grass including watering and maintenance of the lawn for 30 days or more till the grass forms a thick lawn, free from weeds and fit for mowing including supplying good earth, if needed (the good earth shall be paid for separately). 23.10.1 In rows 5 cm apart in both directions. | 150 | 100sqm | | |
| In words: Rs..... | | | | | |
| In Figures:..... | | | | | |

Note: The rate and amount for the above mentioned work has to be submitted in the financial bid only (and not in the technical bid), otherwise the bid will be disqualified from participation in the financial bid.

SPA Bhopal,

Section~7:
Technical Specifications

Table of Contents

| S.N. | Particulars | Page no. |
|------|---|----------|
| 01 | Site information general | 44 |
| 02 | Technical specification Part-I | 44 |
| A | Additional condition | 44 |
| B | Additional specifications | 46 |
| 03 | Technical specification Part-II | 51 |
| A | Additional conditions and specifications for steel & cement | 51 |
| 04 | Technical specification Part-III | 55 |
| A | List of make /brand for various items to be used for work | 56 |

Section~7: Technical Specifications

PREAMBLE

1.0 The Technical Specifications contained herein shall be read in conjunction with the other Bidding Documents.

1.1 Site Information General

1.1.1 The site is situated at Neelbad Road, village - Bhauri, Bhopal. The natural ground condition of the site has good bearing capacity with hard rocky strata.

1.1.2 The area in which the works are located is in plain terrain, the approximate longitude and latitude of the region (Bhopal) being 77° 16” East and 23° 17” North.

1.1.3 Climatic Conditions

1.1.3.1 The temperature in this region is as under:

- i) During summer months, the average maximum temperature is 42°C.
- ii) During winter months, the average minimum temperature is 18°C.

1.1.3.2 The average annual rainfall in the area is of the order of 800mm.

1.1.4 Seismic Zone

The works are located in Seismic Zone-II as defined in IS: 1893(Part I) - 2002

2 GENERAL REQUIREMENTS

The Technical Specifications in accordance with which the entire work described hereinafter shall be constructed and completed by the Contractor shall comprise of the following:

Part-I

Additional conditions, additional specifications and important notes

“A” ADDITIONAL CONDITIONS

1. The work shall be carried out in accordance with the architectural drawings and structural drawings to be issued by the Dean (P & D), the structural and architectural drawings shall at all times be properly correlated before executing any work. However, in case of any discrepancy in the item given in the schedule of quantities appended with the tender and architectural drawings relating to the relevant item, former shall prevail unless otherwise given in writing by the Dean (P & D).
2. The Contractor shall, at his own expense, provide all materials, required for the works. Unless otherwise specified, the materials used on the work shall bear “Standard Mark “of the ‘Bureau of Indian Standards’. It shall be the responsibility of the contractor to ascertain the sources from where the materials having ‘Standard Mark’ are available. The materials, in general, shall conform to the requirements of MATERIALS of The CPWD Specifications.
3. The contractor shall maintain safe custody of materials brought to the site. For Cement and Steel and other materials as prescribed, the quantities brought at site shall be entered in the respective material at site accounts and shall be treated as issued for maintenance of daily consumption. The Cement and Reinforcement Steel shall be procured as per conditions laid down hereunder.

4. Some restrictions may be imposed by the security staff etc. on the working and / or movement of labour, materials etc. and the contractor shall be bound to follow all such restrictions/ instructions and nothing extra shall be payable on this account.
5. Labour will not be permitted to stay in the building under construction.
6. The contractor shall comply with proper and legal orders and directions of the local or public authority or municipality and abide by their rules and regulations and pay all fees and charges which he may be liable and nothing extra shall be payable on this account. The work shall be carried out without infringing on any of the local Municipal Bye-Laws.
7. Any damage done by the contractor to any existing work during the course of execution of work tendered for shall be made good by him at his own cost.
8. The rate for every item of work to be done under this contract shall be for all heights, depths, lengths and widths of the structure (except where specially mentioned in the item) and nothing extra will be paid on this account.
9. The contractor shall take all precautions to avoid all accidents by exhibiting necessary caution boards such as day and night boards, speed limit boards and flags, red lights and providing barriers etc. He shall be responsible for all damages and accidents caused due to negligence on his part. No hindrance shall be caused to traffic during the execution of work. Nothing extra shall be paid on this account.
10. The contractor will work in close liaison, during the works, with other contractors of water supply, sanitary, drainage arrangements, electrical installation and any other works and adjust his work plan accordingly.
11. Other agencies doing work of electrification, external services, other building works, horticulture works etc for this project will also simultaneously execute the works and the contractor shall afford necessary facilities for the same. The contractor shall leave such necessary holes, opening etc for laying/buying in the work pipes, cables, conduits, clamps, boxes and hooks for fan clamps etc as may be required for the electric and sanitary works etc. and nothing extra over the agreement rates shall be paid for the same.
12. The contractor shall keep the site clear thoroughly of rubbish, useless scaffolding and materials etc. from time to time as well as before the actual date of completion of the work as per directions of the Dean (P & D).
13. The contractor shall make his own arrangement for obtaining electric / water connections, if required and make necessary payment directly to the department concerned.
14. Materials brought at site of work shall not be used in the work before getting satisfactory test results. For details relevant provisions in C.P.W.D. Specifications for Works 2009 Vol. I to II shall be referred to.
15. The contractor shall maintain in perfect condition all works executed till the completion of entire work allotted to him.

Dean (P & D)
Institute Works Department
SPA Bhopal

“B” ADDITIONAL SPECIFICATIONS

1. GENERAL

The entire work shall in general conform to the C.P.W.D. Specifications for works **2014 Vol. I to Vol. II** with correction slips issued up to date and description in the Schedule of quantities, additional conditions, particulars, specifications latest relevant Bureau of Indian Standard codes and the drawings. All the above quoted documents shall be considered complementary to each other. However, in case of conflict among the various provisions, the following order of precedence shall be followed.

- i) Provision in nomenclature of item in schedule of quantities, including drawings if any mentioned there in
- ii) Additional Conditions.
- iii) Particulars specifications
- iv) CPWD Specifications.
- v) Latest relevant B.I.S. codes.
- vi) Drawings of the work not specifically mentioned in the nomenclature of the item and
- vii) The decision of the Dean (P & D) given in writing based on sound engineering practice and local usage shall be final and binding on the contractor.

The work shall be executed and measured as per Metric Dimensions given in the schedule of quantities etc. (F.P.S. units wherever indicated are for guidance only).

- 1.1.1. Should there be any difference between the specifications mentioned above and the specifications given in the schedule of quantities, the later shall prevail.
- 1.1.2. If the specifications for any item are not available in the CPWD Specifications cited above, relevant BIS Specifications should be followed.
- 1.1.3. In case BIS Specifications are also not available, the decision of Dean (P & D) given in writing based on acceptable sound engineering practice and local usage shall be final and binding on the contractor.
- 1.2. The work will be carried out in accordance with the architectural drawings and structural drawings to be issued by the Dean (P & D). The structural and architectural drawings shall have to be properly correlated before executing the work.
 - 1.2.1. In case of any difference noticed between Architectural and Structural drawings, the contractor shall obtain final decision in writing of the Dean (P & D).
 - 1.2.2. In case of any discrepancy in the item given in the schedule of quantities appended with the tender and architectural drawings relating to the relevant item, former shall prevail unless otherwise given in writing by the Dean (P & D)
- 1.3. For items where so desired, samples shall be prepared before starting the particular items of work for prior approval of the Dean (P & D) and nothing extra shall be payable on this account.
- 1.4. Materials brought at site of work shall not be used in the work before getting satisfactory **Mandatory test** results. For details, relevant provisions in the CPWD specification shall be referred to.
 - 1.4.1. Wherever it is desired to procure factory-made materials, such factory-made materials shall be procured from reputed and approved manufacturers or through their authorized dealers. The contractor shall obtain the approval from the Dean (P & D) of such firms prior to procurement of such factory-made materials. The Dean (P & D) may, at any stage, inspect such factories/ manufacturing units. The contractor shall have no claim if the factory made materials brought to the site are rejected by the Dean (P & D) in part or in full due to bad workmanship/ quality etc. even after the inspection of the manufacturing units.
 - 1.4.2. The manufactured materials brought at site of work shall, in general, conform to the relevant specifications. The source for supply of the manufactured materials shall be approved by the Dean (P & D). The contractor shall have no claim if the manufactured materials brought to the site are rejected by the Dean (P & D) in part or in full due to bad workmanship/ quality etc.
 - 1.4.3. The preference amongst the various alternative materials available shall be as follows: -

- (a) The materials shall be as per the Brand specified to be used in the work.
 - (b) If the Brand specified material is not available then the material shall be ISI marked.
 - (c) If ISI marked item is not available then it should be from ISO certified Company.
 - (d) If the ISI marked or ISO certified items are not available then the best available items in the market to be procured.
- 1.4.4. Equivalent for the various materials and the materials of approved make shall be got approved from the Dean (P & D) of work in writing before using them on the work.

2. The following modifications to the above specifications shall, however, apply

2.1. Earth Work

- 2.1.1. During excavation and trenching work etc., the contractors shall ensure compliance to the guidelines in such matters laid down by the local body / bodies to ensure that there is minimum hazard to the operating personnel's and users, minimum inconvenience to the users, minimized damage to the underground plant/services of other utilities in a coordinated way, in the interest of public convenience and overall safety.
- 2.1.2. Any trenching and digging for laying sewer lines/ water lines/ cables etc. shall be commenced by the contractor only when all men, machinery's and materials have been arranged and closing of the trench(s) thereafter shall be ensured within the least possible time.
- 2.1.3. Surplus excavated earth which is beyond the requirement of the SPA Bhopal shall have to be disposed of by the contractor at his own cost beyond the municipal limits or at places identified by the local bodies or as directed by the Dean (P & D) after obtaining written permission of the Dean (P & D) and no payment will be made by the Department for such disposal of this surplus excavated earth.
- 2.1.4. The contractor shall, at his own expense and without extra charges, make provision for all shoring, pumping, dredging or bailing out water, if necessary, irrespective of the source of water. The foundation trenches shall be kept free from water while all the works below Ground Level are in progress, without any extra payment.

2.2. Reinforced Cement Concrete Work & Plain Cement Concrete- General

2.2.1. Stone Aggregate.

Stone aggregate to be used in the work shall be of hard broken stone to be obtained from source approved by Dean (P & D) and shall conform to the relevant provisions in the CPWD Specifications.

2.2.2. Fine Sand / Course Sand:

Fine sand / Coarse sand to be used in the work shall be obtained from sources approved by Dean (P & D) and shall conform to the relevant provisions in the CPWD Specifications.

Where only one variety of sand is available, the sand will be sieved for use in finishing work to achieve the required particle size distribution as per CPWD Specifications in order to obtain smooth surface and nothing extra shall be paid to the contractor on this account.

2.2.3. Water: It shall conform to requirements laid down in IS: 456-2000 and CPWD Specification

2.3. R. C. C. work (Design Mix Concrete): Wherever the RCC work is specified to be done with Design Mix Concrete, the particular specifications, as applicable, shall apply.

2.4. R.C.C. Work (Nominal mix concrete) Water-Cement Ratio:

For RCC Works, wherever nominal mix of concrete is stipulated in the items for work, for maintaining proper quality and durability requirements of the structure, maximum water-cement ratio shall be restricted to 0.55. If in normal course of work, the required workability is not achieved; suitable plasticizers/ admixtures may be used for improving the workability of concrete with the approval of Dean (P & D) for which nothing extra shall be paid.

2.5. Non-destructive Testing for Concrete/R.C.C Work:

The Dean (P & D) shall, at his discretion, get the non-destructive testing (Such as Ultrasonic Pulse Velocity Test etc.) done and the Contractor shall make all necessary arrangements for getting such tests done and make good the same after the test, for which nothing extra shall be paid. The results of such tests shall be binding on the Contractor. In case of non-conformity of the test to the standards, the contractor shall be liable to re-do the concrete work at his cost including the cost of test, subject however, to the acceptability of the work as laid down in the mandatory test defined in the relevant CPWD specifications.

2.6. Cement slurry,

if any, added over base surface (or) for continuation of concreting for better bond is deemed to have been in built in the items (Unless otherwise explicitly stated) and nothing extra shall be payable (or) extra cement considered in consumption on this account.

2.7. Centering and Shuttering For R.C.C Work:

The concrete surface shall be free from honeycombing, offsets, superfluous mortar, cement slurry and foreign matter. The formwork shall be assembled in such a way as to facilitate removal of their parts in proper sequence without any damage to the exposed cement concrete surfaces and corners etc. The contractor shall keep skilled staff for special care and supervision to check the formwork and concreting so that every member is made true to its size, shape, level and alignment so that it does not result in any deformation, snag, buldges etc. The contractor shall also take suitable precautionary measure to prevent breaking and chipping of corners and edges of completed work until the building is handed over. The size of shuttering plates for slabs shall not be less than 0.6mx0.9m in general. However, contractor has to provide tape or wooden fillets or rubber gaskets to seal the joint properly to get smooth surface. Further shuttering shall be of such quality that there are no undulations and surfaces will be fairly even and no extra thick ceiling plaster shall be permitted to make the surface even. Any honey-combed or poorly formed concrete shall be repaired with polymer concrete of any suitable design by the Contractor at his own cost, in accordance with the specifications laid down in hand book of Repairs and Rehabilitation of RCC Buildings by CPWD.

2.8. BRICK WORK:

Bricks used in the work shall be M.K.S. to be obtained from kilns approved by Dean (P & D). In all other respects they shall conform to the provisions in CPWD specifications.

2.9. STONE WORK:

Stone used for stone masonry work shall be hard granite/ basalt/ quartz stone/sand stone to be obtained from quarries approved by Dean (P & D) and shall conform to the relevant provision in the CPWD specifications.

2.10. All above materials like stone aggregates, coarse sand, fine sand, Bricks, Surkhi, Stone etc conforming to the CPWD specifications to be brought from the sources approved by Dean (P & D). In case, at any stage during execution of work, the material from the approved source being not available or otherwise, and, is required to be arranged from other sources conforming to relevant CPWD specifications and duly approved of Dean (P & D), involving extra lead etc. nothing extra shall be paid on this account.

2.13 STEEL WORK:

All steel doors, steel windows, steel ventilators, wire gauge, steel glazing, steel grill shall be factory made and obtained from suppliers approved by the Dean (P & D).

- 2.13.1 In the case of composite steel windows the rates shall include the cost of coupling mullion and transom etc. Where windows with inside open able shutters are fixed along-with windows with shutters open able outside, such inside open able windows shall be fitted with suitable friction hinges and open able outside with box type hinges, lever handles or otherwise as approved by the Dean (P & D) of the work. For such windows, cement concrete blocks of size 15cmx 10cmx 10 cm shall be provided nothing extra shall be paid on this account.
- 2.13.2 In the case of steel windows and doors, steel glazing, wire gauge steel ventilators, rolling shutters, grills etc. an approved quality-priming coat of zinc chromates shall be applied over and above shop coat of primer. Nothing extra shall be payable for providing shop-coat primer.

1.14. Sanitary and water supply installations

The contractor shall engage licensed plumber for sanitary, water supply, drainage work and shall be carried out in a manner complying in all respect with the requirement of relevant by laws of the local municipal authority. The Contractor shall give a guarantee to the effect that the work shall remain structurally stable and shall guarantee against faulty workmanship, finishing, manufacturing defects of materials and leakages etc. Contractors shall furnish a Guarantee Bond, as per prescribed format. The Guarantee period shall be for 10 (Ten) years.

- 2.15 **Approval of sample work** of repetitive/typical nature prior to general execution of work shall be as enumerated hereafter.
- 2.15.1.1 Sample of typical portion of the work of repetitive nature such as typical room, toilet room or any other work shall be prepared by the contractor under the directions and to the satisfaction of Dean (P & D) and got approved from him in writing before the commencement of these items for the entire work.
- 2.15.2 The work shall be so arranged to be carried out that the requirement for proportion of sample are observed and fulfilled without any detriment to the general progress of work. In other words, this will not be allowed to have any effect on general progress of work or on any of the terms and conditions of the contract. No claims of any kind whatsoever including the claim of extension of time will be entertained due to the incorporation of this requirement.

Dean (P & D)

Institute Works Department
SPA Bhopal

Part-II**Additional conditions and specifications for steel & cement****GENERAL**

The quoted rates for various items in the tender shall be inclusive of all the additional conditions and particular specifications and for adherence to all these conditions and specifications, no extra payment shall be made to the contractor. Any infringement and/or breach of these specification and condition(s) etc. shall render the contractor liable to action(s) under various clauses of the contract and such action stipulated in conditions therein.

“A” ADDITIONAL CONDITIONS

- i. The Contractor shall maintain safe custody of materials brought to the site. The Contractor shall also employ necessary watch and ward establishment for the work and other purposes as required at his own cost.
- ii. For Cement and Steel and other materials, as prescribed, the quantities brought at site shall be entered in the respective material at site accounts and shall be treated as issued for maintenance of daily consumption.
- iii. The procurement of Cement and Reinforcement Steel, and, their issue and consumption shall be governed as per conditions laid down hereunder.

1. Cement

- 1.1. The contractor shall procure Portland pozzolana Cement 43 grade (Conforming to IS: 1489), as required in the work, from reputed manufactures of cement, having a production-capacity of one million tonnes per annum or more, such as A.C.C. L&T, JK,Vikram, Shri Cement, Gujrat Ambuja Cement and Cement Corporation of India etc. as approved by Ministry of Industry. Government of India, and holding license to use ISI certification mark for their product whose name shall be got approved from Engineer-in-Charge. Supply of cement shall be taken in 50 kg bags bearing manufacture's name and ISI marking. Samples of cement arranged by the contractor shall be taken by the Dean (P & D) and got tested in accordance with provisions of the relevant BIS codes. In case test results indicate that the cement arranged by the contractor does not conform to the relevant BIS codes, the same shall stand rejected and shall be removed from the site by the contractor at his own cost within a week's time of written order from the Dean (P & D) to do so.
1. 2. The Cement shall be brought at site in bulk supply of approximately 50 tonnes or as decided by the Dean (P & D)
- 1.3. The cement godown of the capacity to store about 2000 bags of cement or as decided by the Dean (P & D) shall be constructed by the contractor at site of work for which no extra payment shall be made. Double lock provision shall be made to the door of the cement godown. The keys of one lock shall remain with the Dean (P & D) or his authorized representative and the key of other lock shall remain with the contractor. The contractor shall facilitate the inspection of the cement godown by the Dean (P & D) at any time.
- 1.4 The contractor shall supply free of charge the cement required for testing. The cost of tests shall be borne by the contractor/ Department in the manner indicated below:
 - (i) By the contractor, if the results show that the cement does not conform to relevant BIS codes.
 - (ii) By the Department, if the results show that the cement conforms to relevant BIS codes.

2. Steel:

- 2.1 The contractor shall procure steel reinforcement bars conforming to relevant BIS codes from main producers as approved by the Ministry of Steel or from secondary producers and re-rollers having BIS License to produce CTD bars as specified in schedule –F subject to following stipulations:
- (i) If it is provided in the agreement that steel is to be procured from primary producers and procurement of steel from secondary producers is allowed then a deduction based on the difference in market rate of steel from primary producers and secondary producers shall be made in the running/final bills.
 - (ii) However, if the stipulation is for procurement of steel from secondary producers then if the contractor uses steel from primary producers the same shall be allowed but nothing extra shall be payable on this account.
 - (iii) The contractor shall have to obtain and furnish test certificates to the Dean (P & D). The contractor shall have to obtain and furnish test certificates to the Dean (P & D) in respect of all supplies of steel brought by him to the site of work. Samples shall also be taken and got tested by the Dean (P & D) as per the provisions in this regard in the relevant BIS codes. In case the test results indicate that the steel arranged by the contractor does not conform to BIS codes, the same shall stand rejected and shall be removed from the site of work within; a weeks' time from written order from the Dean (P & D) to do so.
* Deduction item made on account of use of steel from secondary producers instead of primary producers shall not be treated as sub-standard work
- 2.2 The steel reinforcement shall be brought to the site in quantity of lots as approved by the Dean (P & D).
- 2.3 The steel reinforcements shall be stored by the contractor at site of work in such a way as to prevent distortion and corrosion and nothing extra shall be paid on this account. Bars of different sizes (diameters) and lengths shall be stored separately to facilitate easy counting and checking.
- 2.4 For steel procured from main producers, for checking nominal mass, tensile strength, bend test, etc. specimen of sufficient length shall be cut from each diameter of the bar at random at frequency not less than that specified below. In case of works costing more than 2 Crores and when the steel is procured from other than main producers, additional tests such as, retest, re-bend test, elongation test, proof stress may also be conducted

| S.N. | Size (Diameter) of bar | For consignment | |
|------|------------------------|--|--|
| | | Below 100 tonnes | Over 100 tonnes |
| 1 | Under to 10mm dia | One sample for each 25 tonnes or part thereof | One sample for each 40 Tonnes or part thereof |
| 2 | 10mm to 16mm dia | One sample for each 35 tonnes or part thereof | One sample for each 45 Tonnes or part thereof. |
| 3 | Over 16mm dia | One sample for each 45 tonnes or part thereof. | One sample for each 50 Tonnes or part thereof. |
| | | | |

- 2.5 The contractor shall supply free of charge the steel bars required for testing. The cost of tests shall be borne by the contractor/ Department in the manner indicated below:

- 2.5.1 By the contractor, if the results show that the steel does not conform to relevant BIS codes.
- 2.5.2 By the Department, if the results show that the steel conforms to relevant BIS codes.
- 2.6 Coefficient of weight i.e. the weight per unit length of the steel procured by the contractor shall be ascertained at site before using it and certified by the Dean (P & D) In case weight per unit length is beyond the rolling margin as laid down in the BIS: 1786, the steel will be rejected and shall be removed from the site of work within; a weeks' time from written order from the Engineer-in-Charge to do so. In case weight per unit length is more than the standard coefficient of weight for the diameter, but is within the rolling margin, then the payment shall be made as per the standard weight per unit length, and, where the weight per unit length is lesser than the standard coefficient of weight for the diameter, but is within the rolling margin, the payment shall be restricted with respect to the actual weight per unit length of the diameter.
- 2.7 The standard sectional weights referred to in standard table under Para 5.3.3., page 75 of the revised CPWD Specifications 2002 for Cement Mortar, Cement Concrete and RCC works, are to be considered for conversion of length of various sizes of Steel Reinforcement bars into weight and are reproduced below for ready reference.

| SIZE (mm) | WEIGHT (Kg/M) | SIZE (mm) | WEIGHT (Kg/M) |
|-----------|---------------|-----------|---------------|
| 6 | 0.222 | 20 | 2.470 |
| 8 | 0.395 | 22 | 2.980 |
| 10 | 0.617 | 25 | 3.850 |
| 12 | 0.888 | 28 | 4.830 |
| 16 | 1.580 | 32 | 6.310 |
| 18 | 2.000 | 36 | 7.990 |

- 2.8 The actual issue and consumption of steel and Cement on the work shall be regulated and proper accounts maintained as provided in clause 10 of the contract. The theoretical consumption of steel shall be worked out as per procedure prescribed in clause 42 of the contract and shall be governed by conditions laid therein.
- 2.9 Steel and Cement brought to site and remaining unused shall not be removed from site without the written permission of the Engineer-In-Charge.
- 2.10 Cement used in Ready Mix Concrete shall be evaluated based on the certification by the incharge of the RMC Plant in accordance with design approved by the Dean (P & D)
- 2.11 No payment shall be made to the contractor for any damage caused during the execution of work because of cause(s) not covered under Clause 43 of the Contract. The damage to work will be made good by the contractor at his own cost, and no claim on this account shall be entertained.
- 2.12 Some restrictions may be imposed by the security staff etc. on the working and/ or movement of labour, materials etc. and the contractor shall be bound to follow all such restrictions/instructions and nothing extra shall be payable on this account.
- 2.13 The contractor shall comply with proper and legal orders and directions of the local or public authority or municipality and abide by their rules and regulations and pay all fees and charges which he may be liable and nothing extra shall be payable on this account. The work shall be carried out without infringing on any of the local Municipal Bye-Laws.
- 2.14 The contractors shall given a performance test of the entire installations as per standard specifications before the work is finally accepted and nothing extra what so ever shall be payable to the contractor for the tests.

- 2.15 The rate for every item of work to be done under this contract shall be for all heights, depths, lengths and widths of the structure (except where specially mentioned in the item) and nothing extra will be paid on this account.
- 2.16 The contractor shall take all precautions to avoid all accidents by exhibiting necessary caution boards such as day and night boards, speed limit boards and flags, red lights and providing barriers etc. He shall be responsible for all damages and accidents caused due to negligence on his part. No hindrance shall be caused to traffic during the execution of work. Nothing extra shall be paid on this account.
- 2.17 The contractor will work in close liaison, during the works, with other contractors of water supply, sanitary, drainage arrangements, electrical installation and any other works and adjust his work plan accordingly.

2.18 Other Taxes and Royalties

- 2.18.1 **Income Tax and surcharges over Income Tax etc.** at the rates fixed by the Ministry of finance, Government of India shall be deducted from all the running and final bills of the contractor. Should there be any increase in rate of Income Tax and surcharge during execution of the contract, the same shall be payable by the contractor.
- 2.18.2 **Works Contract Sales Tax** as prevalent as per statutory orders of State/Central Government and shall be charged on gross value of all the bills and shall be recovered from each bill of the contractor as 'works contract sales tax'. Should there be any increase in rate of Works Contract Sales Tax during execution of the contract, the same shall also be payable by the contractor.
- 2.18.3 **Labour & Building Workers Tax** as prevalent as per statutory orders of State/Central Government and shall be charged on gross value of all the bills and shall be recovered from each bill of the contractor as 'Labour & Building workers tax'. Should there be any increase in rate of Works Contract Sales Tax during execution of the contract, the same shall also be payable by the contractor.
- 2.18.4 **Royalty** shall have to be paid by the contractor on all materials such as stone, bricks, boulders, metal, shingle, bajri, stone aggregate, coarse sand and fine sand etc. or any other materials used for the execution of the work direct to the Revenue Authority of the District/State Govt, concerned. The contractor shall obtain "No Demand" certificate from the District/State Govt authority concerned before the final bill is paid, failing which necessary recovery will be effected at the applicable rates in the final bill.
- 2.18.5 The contractor shall have to bear the cost of non-judicial stamp paper of appropriate value for preparation of contract agreement of the work.

2.19 Secured Advances:

- 2.19.1 Secured advance on bricks, stone, stone aggregate brought at site for use in the work shall be paid only after receipt of satisfactory test results from the laboratory and provisions under rules.
- 2.19.2 Secured advance on steel doors, steel windows, etc. shall be paid only after the Dean (P & D) has personally verified that the materials brought at site of work, for use in work, conform to the sample approved by him.
- 2.19.3 Secured advance whenever admissible on water supply, sanitary installation materials and fittings shall be allowed only after the Dean (P & D) has verified that materials brought at site have been checked by him personally and are in conformity with the samples approved by him.
- 2.19.4 Secured advance for terrazzo tiles shall be paid only after satisfactory results are received from the laboratory.

Part-III**List of make/brand for various items / products to be in work**

Name of Work: Construction of football ground with stage for SPA Bhopal at Bhauri, Bhopal (M.P.)

| S. No. | Material / article | Conforming IS code | Manufacturers / Agencies / brand / make |
|--------|---------------------|----------------------|---|
| 1 | Cement | IS 1489(Part 1) 1991 | Portland pozzolana Cement 43 grade (Conforming to IS: 1489) from reputed manufactures of cement such as A.C.C. L&T, JK,Vikram, Shri Cement, Gujrat Ambuja Cement and Cement Corporation of India etc. as approved by Ministry of Industry, Government of India, and holding license to use ISI certification mark for their product whose name shall be got approved from Dean (P & D)) |
| 2 | Steel Reinforcement | IS 1786:2008 | Steel reinforcement bars conforming to relevant BIS codes from main producers as approved by the Ministry of Steel Thermo mechanically treated cold twisted bars Fe-500conforming to IS 1786:2008from approved brands like SAIL,TATA TISCO, RINL,JINDAL etc. |
| 3 | Sand | ~ | River sand, Crusher stone dust(source/crusher for sand/stone dust to be approved by Dean (P & D)) |
| 4 | Pvc Pipe | IS : 13592 | Swastik,supreme,kisan |
| 5 | Steel Section | ISI Mark | Jindal,Tata,swastik |

NOTE:

1. For any other make, prior approval of Dean (P & D) SPA Bhopal is required before execution in work.
2. All mandatory tests and other tests shall be made as per the departmental guidelines applicable and as required by Dean (P & D) SPA Bhopal

Dean (P & D)
Institute Works Department
SPA Bhopal

CERTIFICATE

I/we hereby undertake that I/We/My authorized representative have received the copy of the stated list (along with the tender document) of brand names of various items to be used for the above work and I/We shall quote my rates of various items of schedule accordingly. I hereby also certify that I shall use only the above referred brands in the work and in case any other brand is used then I shall not claim for the payment of that item.

Signature of Contractor
or his authorized representative with Seal

**Section-8
Drawings**

(Strictly for Tender Purpose Only)

List of Drawings

| S.N. | Particulars | Page no. |
|------|-------------|----------|
| 01 | Drawing | i |

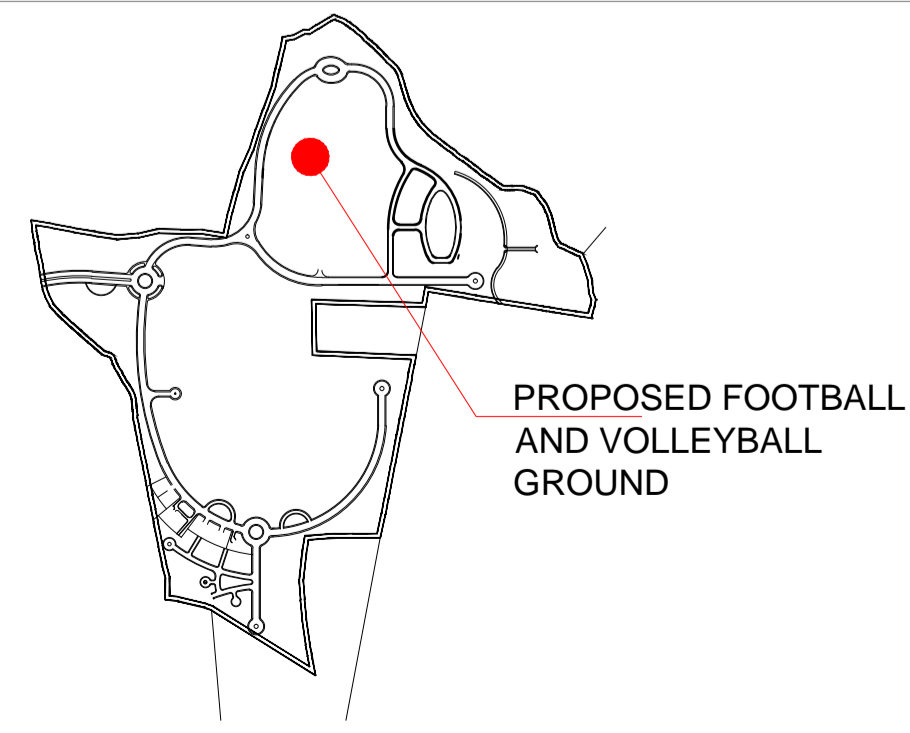
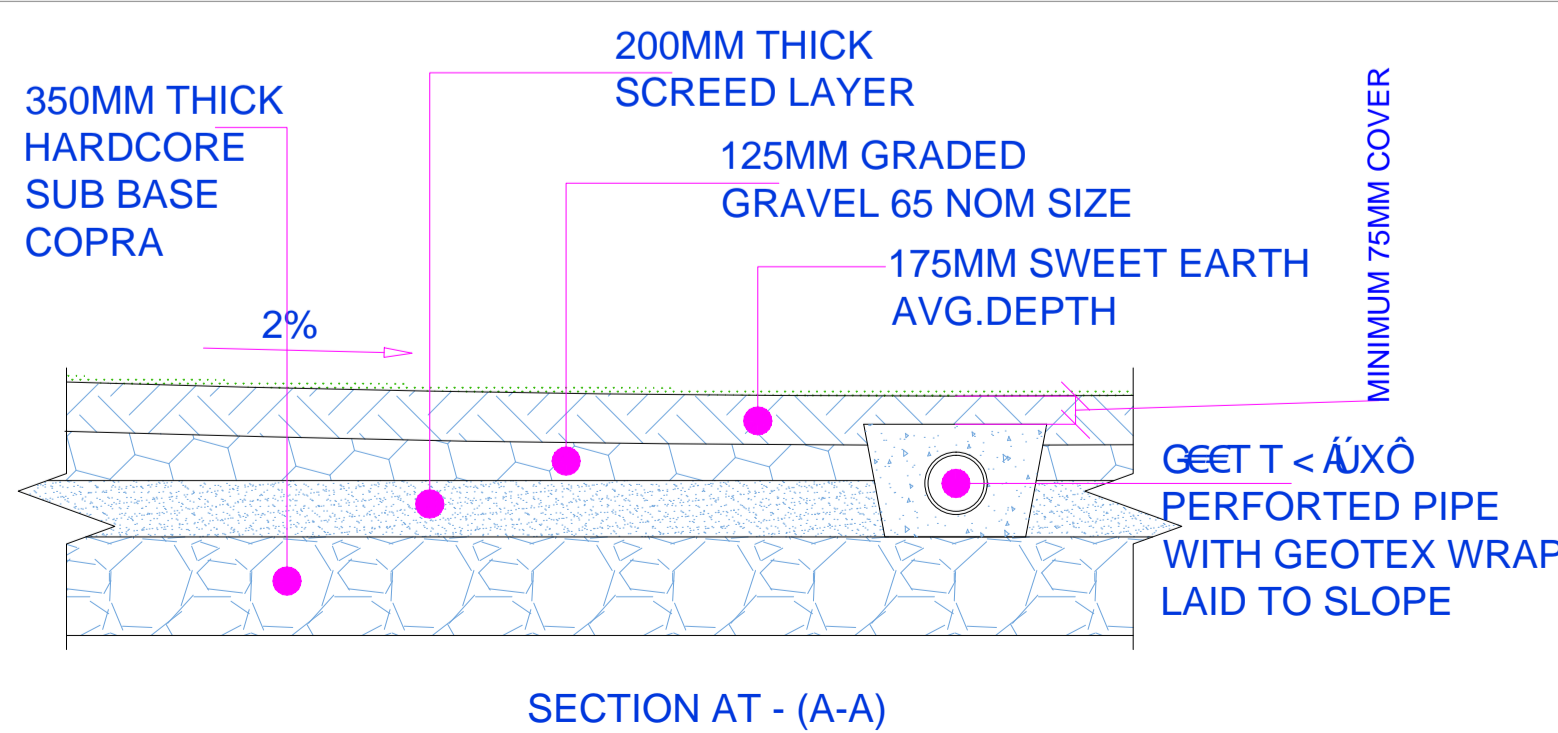
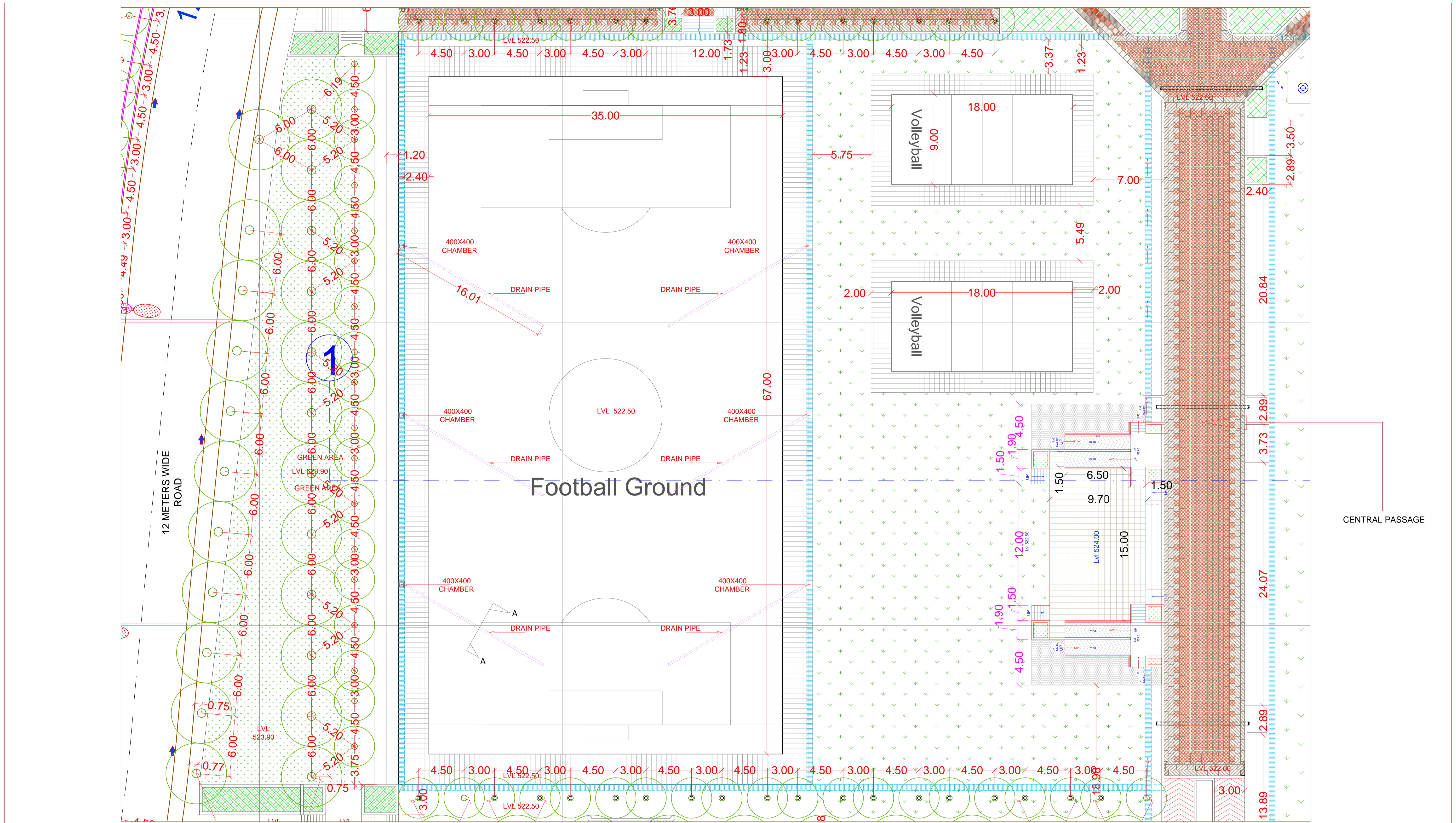

PROJECT:
 PROPOSED LANDSCAPE PLAN OF SPA BHOPAL AT KHASHRA NO. 13/1/1 VILLAGE BHAURI, PATWARI HALKA NO.34, REVENUE CIRCLE -4, FANDA, TEHSEEL HUZUR, DISTRICT BHOPAL, MP

NOTE:-
 01. This drawing is copyright and property of 'SPA BHOPAL' and is not to be reproduced, copied, or used for any other purpose.
 02. All dimensions shall be checked on the prior to commencement of work.
 03. Written dimensions shall be followed.
 04. Any change required shall be confirmed from the architect prior to commencement of work.
 05. This drawing shall be read in conjunction with other pertinent drawings.
 06. If there is any discrepancy, it shall be referred to the architect for clarification.
 07. All dimensions are in meter.

| | | | | |
|--|---|--------------|--------------------|-----------------------------|
| DESIGNED BY: AR. A.K. VINODIA ASSO. DEAN (P. & D.) | SHEET TITLE: PROPOSED PLAYGROUNDS AT SCHOOL OF PLANNING AND ARCHITECTURE BHOPAL. | | | Compass N W E S |
| | N.F.C. REV. NO. | CHECKED BY | DATE | |
| APPROVED BY: DEAN (P. & D.) | DRAWN BY AR. VEERENDRA | PROJECT. NO. | DATE 07-05-2015 | DWG. NO. A2 1:100 |
| | CONSULTANTS: INSTITUTE WORKS DEPARTMENT SCHOOL OF PLANNING AND ARCHITECTURE BHOPAL. SITE OFFICE BUILDING, BHAURI CAMPUS, NEELBAD ROAD, BHAURI, BHOPAL-31 | | | SPAB/IWD/LC-PL/01 |